



FRENCH-EGYPTIAN CENTRE FOR THE STUDY OF THE TEMPLES OF KARNAK



Luxor, 2017



*Ministry of Antiquities of Egypt
Centre National de la Recherche Scientifique
Ministère des Affaires Étrangères et du Développement International*

FRENCH-EGYPTIAN CENTRE FOR THE STUDY OF THE TEMPLES OF KARNAK

ACTIVITY REPORT 2016

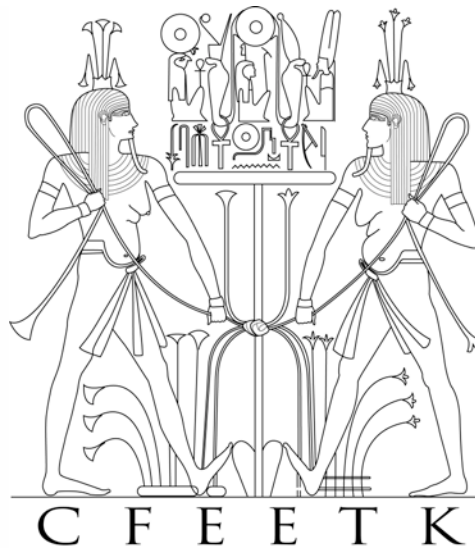

TABLE OF CONTENTS

FOREWORD	4
1. SCIENTIFIC PROGRAMMES	7
1.1. Power and marks of Power at Karnak	7
1.1.1. The Sphinx of Pinudjem.....	7
1.1.2. The 8th Pylon	7
1.2. Peripheral areas	9
1.2.1. The Temple of Ptah	9
1.3. Cults and places of worship	28
1.3.1. The Monuments of Amenhotep I	28
1.3.2. The Osirian sanctuaries	31
1.3.3. The Bark-shrine of Philipp Arrhidaeus	41
1.3.4. The Central sanctuaries of the <i>Akh-menu</i> and the “Northern storerooms”	41
1.4. The <i>Karnak</i> project	42
2. RECONSTRUCTION PROGRAMMES.....	44
2.1. The Calcite chapel of Tuthmosis III	44
2.2. The columns of the “Northern storeroom” no. 2	50
2.3. The walls of the Cachette courtyard	51
2.4. The gate of the southern Bubastite portal	51
3. CONSERVATION-RESTORATION PROGRAMMES	52
3.1. The Sphinx of Pinudjem	52
3.2. The Temple of Ptah	56
3.3. The “Northern storerooms” of the <i>Akh-menu</i>	62
3.4. The vestibule of the Alexander the Great’s chapel.....	67
4. ARCHIVES AND SCIENTIFIC DOCUMENTATION	74
4.1. Scientific archives.....	74
4.2. Photographic department	76
4.3. Topographical department	76
4.4. The scattered blocks survey	77
5. TRAINING PROGRAMMES	78
6. PUBLICATIONS AND LECTURES	79
6.1. Selected publications of the CFEETK members and associated missions (2016)	79
6.2. Colloquium and lectures.....	82
6.3. Press releases	83
7. CFEETK MEMBERS	83
8. ACADEMIC COLLABORATIONS.....	84
9. SUBMITTED PROGRAMMES OF THE CFEETK FOR 2017.....	86

FOREWORD

Work of the French-Egyptian Centre for the Study of the Temples of Karnak in 2016 mostly took place on schedule, in accordance with the four years programme 2013-2016 and the decisions of the Scientific Committee which took place in February 2015. Inside the temple, the activity of the Centre was mainly involved in three programmes, as an extension of the work of the previous seasons.

The first concerns the archaeological investigations of the southern and eastern areas of the Ptah temple; a deep sounding has made possible to uncover the first stages of the occupation in this area, dating back to the Middle Kingdom. On the eastern part, excavation brought to light a settlement of the Roman-Byzantine period.

The second programme was devoted to the conservation and restoration work in the area of the Alexander the Great's chapel, inside the *Akh-menu*, and in the "Northern storerooms" of Tuthmosis III; the area of the storerooms was completed and is now opened to visitors.

After some restoration and a final cleaning, the reconstruction programme of the chapel of Tuthmosis III was completed and the chapel was also opened to visitors after an official visit of H.E. Pr. Dr. Khaled el-Enany, Minister of Antiquities.

The epigraphic work continued at the 8th pylon and inside the *Akh-menu* and the "Northern storerooms". For the Philipp Arrhidaeus' bark-shrine the work is now finished on the field.

The online edition of all the hieroglyphic texts from Karnak (the *Karnak* project) started in January 2013; it is funded by LabEx Archimede (CNRS UMR 5140-Univ. of Montpellier III-Univ. of Perpignan). In 2016, the *Karnak* project provided 4,000 hieroglyphic inscriptions of the temple of Karnak available online. The scientific archives of the Centre have been opened online this season.

Constant work has concerned the documentary database of Karnak, which was enhanced by the addition of photographs and new scans. The website of the Centre received 320,000 visitors this year.

With the help of Dr. Hussein Bassir, the *Cahiers de Karnak* 15 has been published on the MoA press. The issue 16 will be published in 2017, celebrating the 50th anniversary of the Centre. A book about the work of the Centre will also be published to celebrate this event. The epigraphic and photographic survey of the Temple of Ptah (*Le temple de Ptah à Karnak I-II*) has been published on the IFAO press; other volumes are in preparation. Also, three other books have been published this season.

All the work carried out at Karnak has benefited from the constant help of Amin Ammar, General Director of Karnak temples, Abder Raheem Khazafi, Director of Karnak Temples, Mona Fathi and Fawzy Helmi, Directors of Karnak Temples, Abd al-Satar Badri, Director of scientific researches, Tayeb Gharib and Ghada Ibrahim, chiefs inspectors, Abdel Nasser Ahmed, Chief conservator, Tarek Milad Zikri, Chief architect of Upper Egypt, all the inspectors, the Raïs Mahmud Faruk and the workers of the MoA. It is a pleasure to thank all of them for their kind and constant support.

We would like to extend our grateful thanks to the French authorities of the *Centre National de la Recherche Scientifique* and of the *Ministère des Affaires Étrangères et du Développement International* for their constant financial support and interest on the programmes led by the CFEETK.

We are always delighted with the excellent relationships between the French-Egyptian Centre for the Study of the Temples of Karnak and the *Ministry of Antiquities of Egypt* led by H.E. Minister of Antiquities Pr. Dr. Khaled el-Enany.

Dr. Mohamed Abdel Aziz
General Director of Upper Egypt Antiquities (MoA)

Dr. Christophe Thiers
Director of the USR 3172 (CNRS)

Amun-Re Temple, main fieldwork in 2016

(as submitted at the Scientific Committee in February 2015)

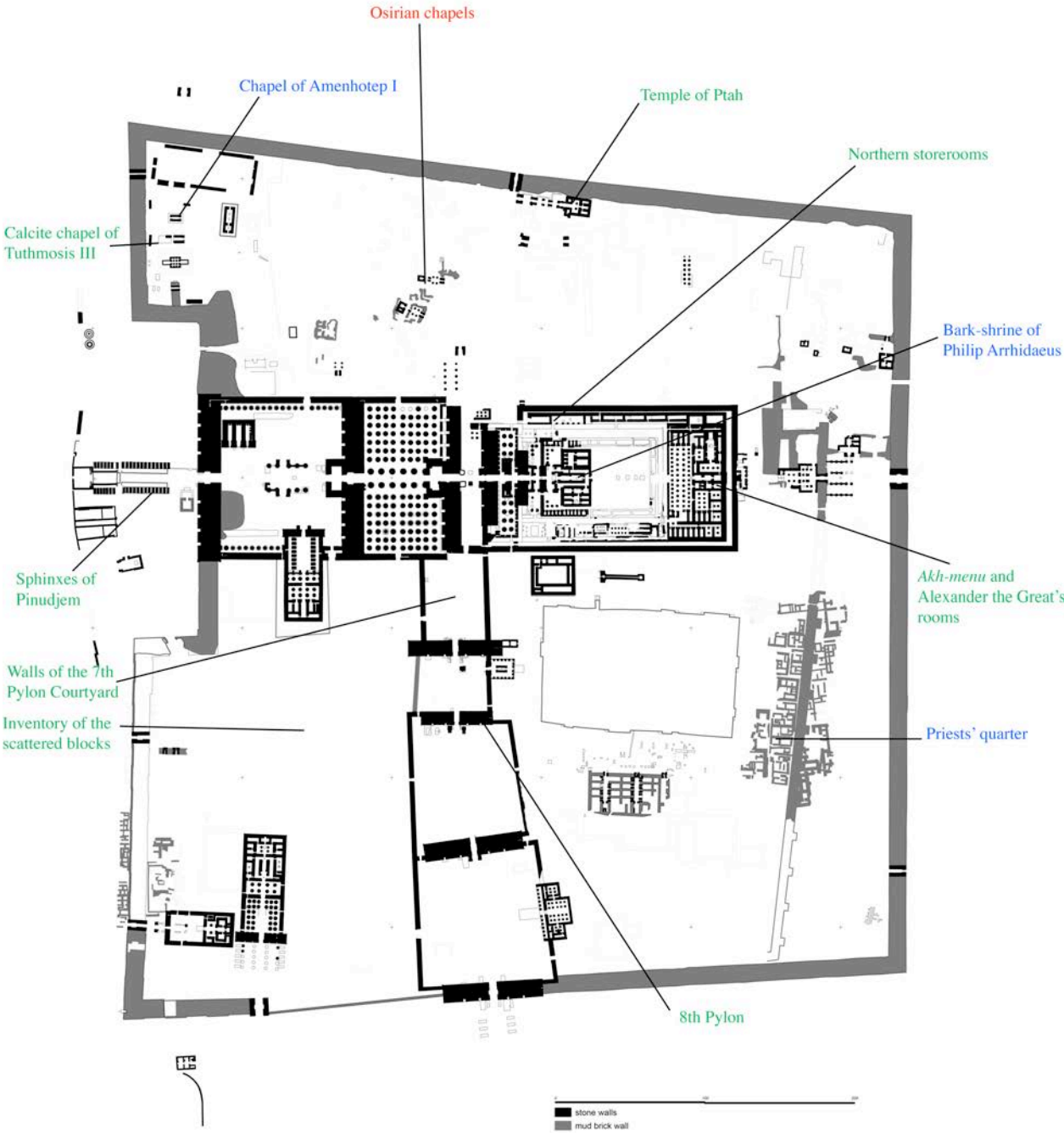

Temple of Ptah : main CFEETK projects
Osirian chapels : projects hosted by CFEETK
Priests' quarter : projects currently in publication

1. SCIENTIFIC PROGRAMMES

1.1. POWER AND MARKS OF POWER AT KARNAK

1.1.1. The Sphinxes of Pinudjem I (G. Dembitz, S. Biston-Moulin, Chr. Thiers)¹

The study and the epigraphic documentation of the inscriptions of Pinudjem I carved on the sphinxes continued in March-June 2016.

The epigraphic documentation of the inscriptions carved onto the fronts of the plinths of the sphinxes of the southern row in the Great Court and of the southern row of the Dromos had been completed. We also completed the documentation of the uniform inscriptions of Pinudjem I carved on the side and rear parts of the plinths of the sphinxes of the northern row of the Dromos (PAR.DO.sp3.n; PAR.DO.sp5.n – sp19.n).

In order to be able to document their inscriptions, the fronts of the plinths of the sphinxes designated as GCR.SS.sp10-14 had to be restored between April and May 2016.

The photographic documentation of loose blocks currently stored in the Great Court of the Karnak Temple, and originally belonging to the processional avenue during the time of Pinudjem I, has begun in June 2016.

Bibliography

- G. Dembitz, “La liste géographique de Pinedjem I^{er} à Karnak – Résultats préliminaires sur l’allée des sphinx de Karnak-ouest” destined to the forthcoming proceedings of the international conference “*Au-delà du toponyme. Approche interdisciplinaire de la territorialité. Égypte et Méditerranée anciennes*” that took place in October 2015 in Montpellier.

1.1.2. The 8th Pylon (S. Biston-Moulin, E. Frood)³

The photographic survey carried out with the orthophotographs technique to produce very high-resolution documents enabling to draw from digital files has been completed this year. Most of the facsimiles have been completed. The correction of the facsimiles by control of the original began this year and will continue next year.

Work on recarved elements of the inscriptions until the initial state decoration dating back to Queen Hatshepsut and numerous alterations began this year and will continue next year.

All the inscriptions copied within this epigraphic survey and high resolution photographic documentation were incorporated into the *Karnak project*.

¹ With Mamduh Abd el-Ghassul (MoA-CFEETK).

³ With Ch. Salvador (univ. Oxford).

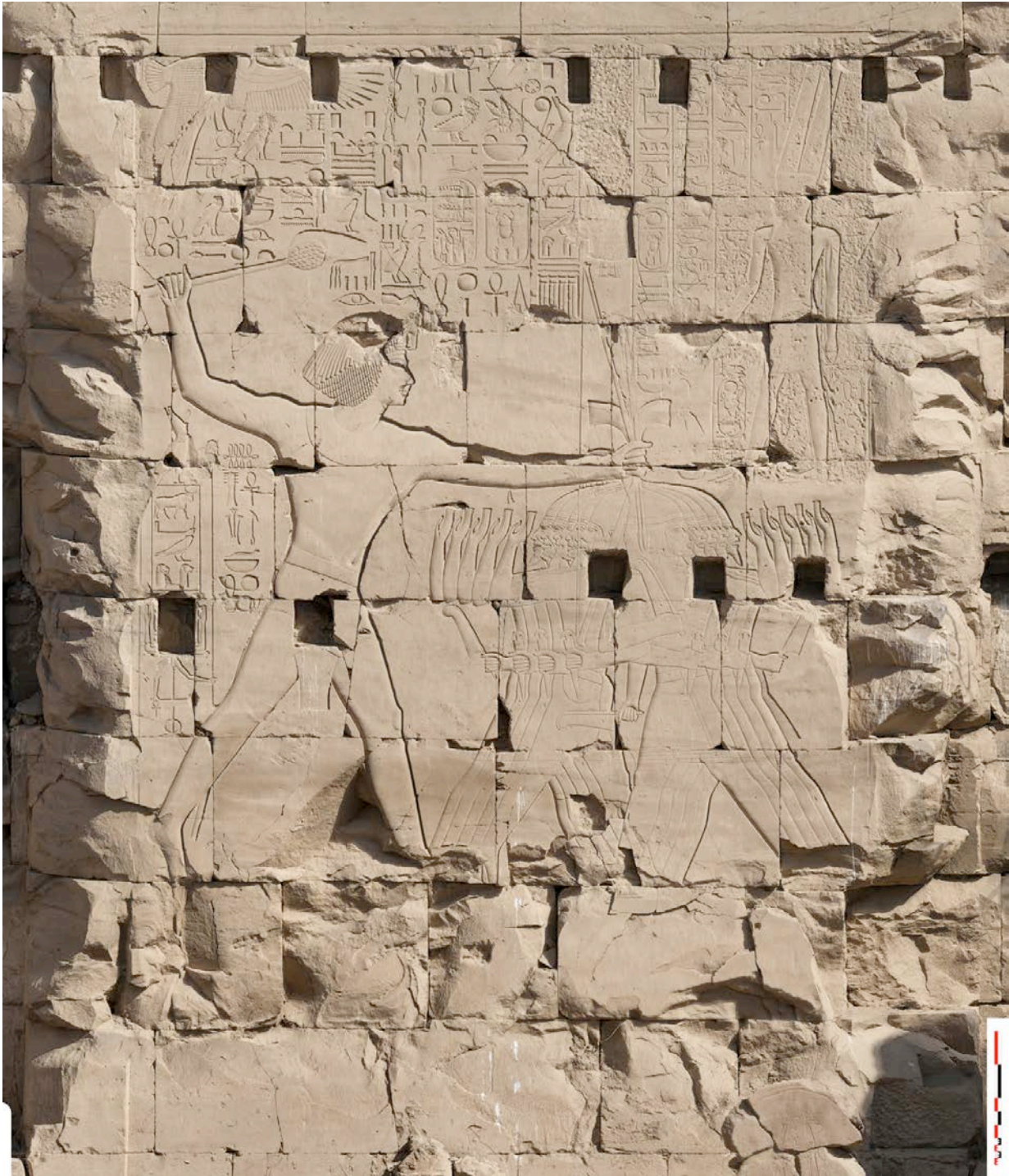

Example of orthophotograph of the central scene of the south face of the west part of the 8th pylon.
© CNRS-CFEETK/Ph. Soubias.

1.2. PERIPHERAL AREAS

1.2.1. The Temple of Ptah (G. Charlux, M. Ali al-Abady, St. Boulet, B. Durand, P. Mégard, A. Nasseh)⁴

The archaeological operations during the 2015-2016 campaign focused on areas east and south of the Ptah temple at Karnak, like last year. The objectives remained unchanged, i.e. to define the extension of the temple during its last stage of use – by clearing the eastern part of the so-called Ptolemaic enclosure, but also to understand the evolution of its immediate surroundings, and to get a more complete picture of the Roman-Byzantine settlement on the vast artificial terrace situated in the east of the temple.

Various collective activities were added to the excavations, especially the complement of survey of mudbrick structures in the western part of the area that had not been completed in previous seasons, the recording of all the archaeological documentation in a relational database, as well as the geophysical exploration of the sector of the Ptah temple and of the southern part of the Karnak temple.

We must not of course forget in this list the training of two highly motivated Egyptian archaeologists, Mona Ali al-Abady and Ahmed Nasseh, MoA inspectors, who participated daily to the excavations and to the recording.

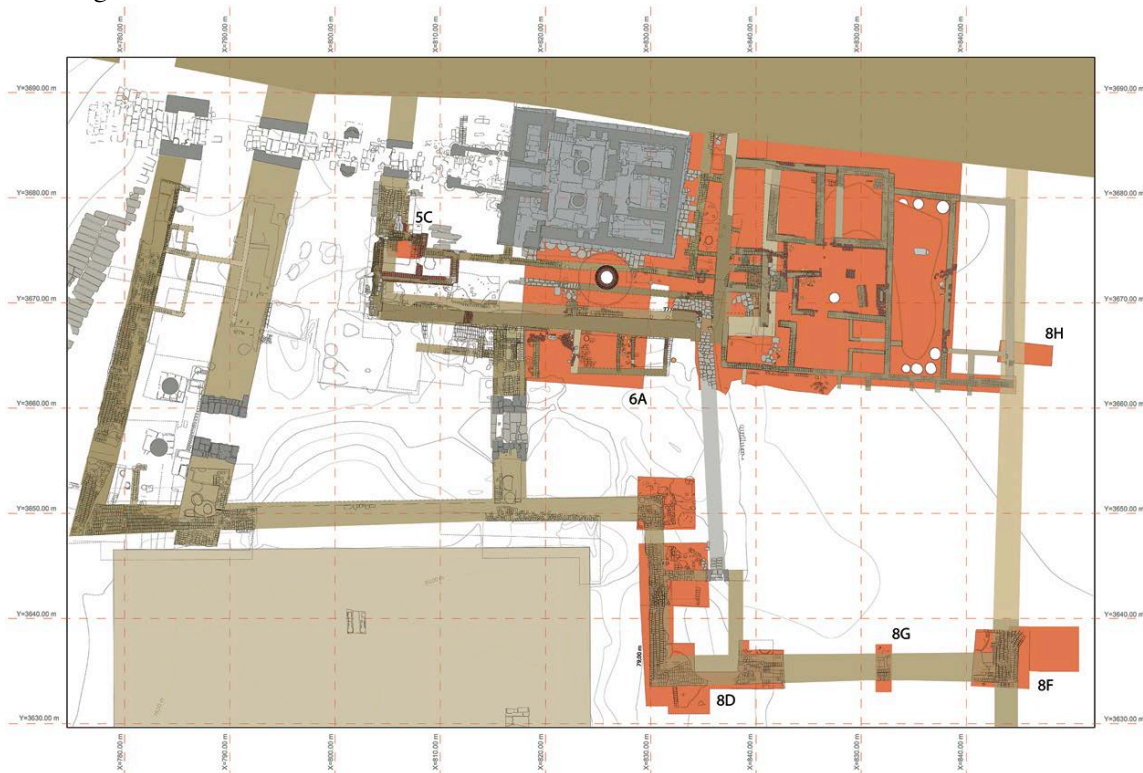

General plan of the sector of the temple of Ptah in Karnak at the end of 2015-2016 season. In orange, the excavated areas in 2014-2016.

⁴ With Florian Camus, Marjorie Riou (CNRS trainees), Saddam Mohamed Saddeq (MoA Inspector), and Florie Pirou (CFEETK-Labex Archimede). This programme operates with the support of the LabEx ARCHIMEDE, “Investissement d’Avenir” programme ANR-11-LABX-0032-01, in the framework of the programme “Expressions du pouvoir royal à Karnak : entre édification de l’espace sacré et construction du territoire urbain, le temple de Ptah à l’étude.”

Excavations of the Ptolemaic enclosure of the temple (G. Charloux, A. Nasseh)

The clearing of the extension of the so-called Ptolemaic enclosure was continued during the 2015-2016 campaign, in an attempt to delineate the extension of the temple to the east. In this perspective, three soundings 8F, 8G and 8H were opened after extending sounding 8D south and east. Excavations have followed the methodological principles established in 2015, to save time of search and analysis of furniture: the clearing of the surface of the enclosure without getting down into the adjacent layers.



Surface cleaning and apparition of the enclosure wall towards the south. © CNRS-CFEETK.

The mudbrick wall was cleaned easily on around twenty meters south before making a right angle toward the east. Its exterior angle is well preserved, while the inside corner is in turn disrupted by a large pit filled with beige gray silt powder.

After a necessary descent in a vast disturbed area to the east, the faces of structure were brought to light without difficulty, especially as some gray ashy layers located around two partially highlighted silos enabled to view its facing north.

This operation also highlighted a new north-south mudbrick wall abutting the northern face of the enclosure. The wall delimitates a large room south of small door C' attributed to Ptolemy III, according to G. Legrain (Communication Chr. Thiers). Given the numerous disturbances, it is expected that there remains few traces of the initial state of this space, perhaps a storeroom or a chapel.

The enclosure was then followed in soundings 8G and 8F.

As shown by soundings 8C and 8D, but also the most westerly soundings previously, the settlements from the Ptolemaic to late Byzantine periods leaned against the enclosure and gradually reduced its thickness in order to enlarge the internal spaces. If a late occupation is apparent beyond the perimeter wall 8F, it is quite likely that the role of protection or of subdivisions of the enclosure was kept during the Roman-Byzantine period.



Sounding 8F at the end of the cleaning. © CNRS-CFEETK.

A stratigraphic sounding south of the temple of Ptah (G. Charloux, M. Ali al-Abady)

In continuation of research conducted in 2014-2015 on the archaeological remains located in the immediate vicinity of the temple of Ptah, it was decided to open a broad stratigraphic sounding to the south of the temple. This sounding of 12 m square has caught our attention from October 2015 to February 2016, with few verifications in April.

The aim of this large-scale operation was to establish a stratigraphic reference for the sector of the temple of Ptah, in particular to determine the first period of construction of the temple and to better determine the pace of its evolution but also the strategic choices of development for the area.



General view of the excavation. © CNRS-CFEETK.

To comply with maximum safety rules, the sounding was conducted in an inverted pyramid in steps of 1 m in height and width, according to conventional methods in French metropolitan archaeology. Once each level achieved, the space was reduced by 1 m on all sides. We have proceeded to the clearance of 6 levels of 12 x 12 m, 10 x 10 m, 8 x 8 m, 6 x 6 m, 4 x 4 and 2 x 2 m, and have removed nearly 320 m³ of earth in six months. To conduct this research, the 10 specialized workers in archaeology at CFEETK were solicited, to which 9 external workers were added. Technical support was provided by P. Mégard, GIS specialist and topographer for the realization of orthophotos and CAD. As usual, the floor or foundation layers were fully sieved and thus delivered a significant amount of furniture to study. The ashy layers, some floor layers and few mud bricks were sampled for archaeobotanical analysis and 14C dating.



Sieving of archaeological layers. © CNRS-CFEETK.

Excavations have revealed 30 distinct archaeological states (including 2 Byzantine states and two states of the Ptolemaic period excavated by B. Durand) over 7 levels from the altitude 76.80 m to 71.60 m. The stratigraphy over 5 m deep delivers a comprehensive overview of the 2700 years of site occupation, from its geological formation to its abandonment. The main diachronic events are organized around the identified levels: the geological substrate (level 0) was reached under a phase of erosion and of temporary human use of the ancient banks of the Nile river (Level 1). Then, followed a succession of domestic occupation phases (Level 2), a first abandonment of the sector (Level 3), a stage of civil constructions (Level 5), and a new period of abandonment (Level 6). The first enclosure south of the temple (Level 7) deeply cuts the lower levels. The impressive superposition of mudbrick enclosures south of the Ptah temple testifies to the sustainability of function of the sector and the reuse of religious facilities for civilian use from the Roman-Byzantine period until the final abandonment of the sector (level 7, state 30).

Level 0

The geological substrate appeared in the southeastern corner of the 4x4m square. It is a thick layer of grey-yellow river sand virgin of material which has a steeply slope, characteristic of a river soil profile. A manual augering was conducted and went down 6 m to check the substrate nature.

Level 1

This level corresponds to a massive sedimentation of the banks of the Nile in ancient times, marked in particular by an increasingly intense anthropisation until the first domestic constructions of level 2. Two phases 1 and 2 have been identified for this level.



Manual augering at the bottom of the sounding.
© CNRS-CFEETK.

Level 2

Level 2 (phases 3-9) is the first phase of building activities in the sector. Each stage of the studied habitat is marked by a gradual soil accumulation of dust and organic and anthropic material. The floors are not built specifically and no preparations were observed, particularly in relation to the base of the walls. Only more compact or dense areas have occasionally been noticed. Soils have therefore been identified depending on the location and density of archaeological material and the presence of ash layers and hearths. Each phase of this certainly civil settlement, specifically domestic, delivered fauna, pottery, flint tools and few seals impressions.



Discovery of mudbrick remains from Level 2. © CNRS-CFEETK.

Level 3

The previous level ends with the abandonment of the houses and the collapse of the mudbrick structures. The thick walls to the east and south are kept rather high to the north and west, creating a square central depression.

Two states 10 and 11 occurred in Level 3: the spreading of ashes reveals a short living phase following the collapse of the walls of the prior level, before an episode of covering by a layer of gray silty sand with very little material.

Level 4

The level 4 attests of a short stage of domestic activities, then of a period of indefinite human action. The phase 12, very patchy because of the diggings of later phases 14-17, is identified by a dark gray ash layer that extends over the entire open space. To the east, a concentration of bread molds was discovered in a small area.

The following phase (13) is materialized by a rather thick layer of brown-beige clayey silt with many mudbricks, possible an artificial embankment.

Level 5

The first monumental developments appear in Level 5 (phases 14 and 15). Massive and well orthogonal mudbrick foundations deeply cut into the lower Levels 3 and 4. Two phases, very comparable, without floor, occurred in the square and seem to show the evolution of a large building with public character.



Excavation of some successive phases at the same time (14-16). © CNRS-CFEETK.

Level 6

Level 6 (phases 16-17) testifies of a new stop in the installation and function of the sector. As indicated by the absence of destruction layer (Level 5), a substantial leveling of the area occurred at the end of the phase 15. This was of such a magnitude that it damaged deeply the foundations of the walls of the previous state.

The digging and filling of a large pit, cutting the remains of two previous phases, were operated after these leveling activities, as confirmed by the covering of the depression on the surface of the pit by a thick layer of silty sand.

Level 7

Level 7 attests of the implementation of the first temple of Ptah. Five enclosures, wider at each phase, will overlap over time, without changing their axis, and despite the transformations made to the temple of Ptah during the thutmoside period. The initial architectural blueprint of all vestiges adjacent to the religious building will be preserved until the abandonment of the sector.

Note that the excavated walls are the lower parts of the foundations of the enclosures that have been leveled at each new construction. The exposed layers are essentially fillings. No floor or circulation level was observed before the phase 24, which marks the beginning of the Ptolemaic settlement, perhaps of artisanal character. We then observed six states in civilian occupations from Ptolemaic to Byzantine times.



Level 7 during excavation. © CNRS-CFEETK.

Study of a red brick well (M. al-Abady, G. Charloux, B. Durand)

The study of a well made of fired red bricks and identified in the previous season south of the temple of Ptah was conducted by G. Charloux, assisted by M. Ali al-Abady, during the stratigraphic analysis of sounding 6A in 2015-2016. It was completed in April and early May 2016 by B. Durand who dug inside the structure.

While the masonry had previously been observed only in the section of the foundation pit of the temple of Ptah last year, excavation has permitted us to clean its surface and a portion of its perimeter this year, as well as to better understand its general implementation.

The removal of the filling of the pit surrounding the red brick structure showed that the pit has a more or less frustoconical shape, due to the digging of a spiral staircase in the lower archaeological states. The role of this staircase was only the digging of the pit and the building of the well. It was fully blocked by a clay loam filling in which many pottery sherds and fragments of red bricks were found.



The stairs inside the foundation pit of the well. © CNRS-CFEETK.

As it was not possible to go down deep inside the well, the goal was to get as much archaeological artifacts as possible in the accessible layers to refine the dating of the abandonment, but also, in the best case to demonstrate a late use of the adjacent temple. The search, however, has not reached the bottom of the well: its filling has a total depth of 8.7 m.

To sum up, this short archaeological operation has uncovered a beautiful Byzantine civil structure, which is, however, very common in the region. The detailed review of its development, however, allowed to highlight some original construction details, rarely evoked in the archaeological literature in Egypt. The study of the ceramic assemblage should perhaps help clarify the date of its abandonment and filling. It will be hardly possible to continue the excavation of wells in the future without additional logistics.



View of the well after removal of the first red brick courses.
Note that the well was rebuilt at the end of the season. © CNRS-CFEETK.

The Byzantine settlement east of the temple of Ptah (B. Durand)

Works on the area located east of the temple of Ptah were conducted during two periods respectively from the 15th of September to the 17th of December 2015 and from the 16th of April to the 5th of June 2016. The archaeological remains date back to the last period of occupation of the site to the late fourth - early fifth century AD, according to the study of the pottery (analysis by Romain David by the end of year 2015). The methodological approach is that of an extensive horizontal excavations - and if possible exhaustive – of what can be designated as a “Byzantine” settlement. Unlike previous studies, the approach here is synchronic, only the surface remains being cleared.



General view of the Byzantine settlement east of the temple of Ptah. © CNRS-CFEETK/É. Saubestre.

This settlement seems to be confined within a defined perimeter. The sector is delimited by the excavations of the Treasury of Shabaka located a few dozen meters to the east. To the north is the imposing enclosure of Nectanebo which sets a “natural” limit to the extension of the living area. To the west, the search is now limited by the Ptolemaic pavement connecting the temple to the Ptolemaic door C’ (see Charloux *et al.*, report 2015). To the south, the clearing of the Ptolemaic enclosure wall may have delivered the southern boundary of the settlement. The dimensions of this space can be estimated at approximately 47 m from north to south and 32 m from east to west, which corresponds to an area of approximately 1500 sq m. This surface, which remains hypothetical, has already been excavated on a surface of approximately 480 sq m, slightly less than a third.

The primary objective was to define a general plan of the Byzantine occupation by clearing the structures on surface. Nonetheless, every spaces were excavated to the floor.



Staging of restored pottery in the kitchen around a fireplace. © CNRS-CFEETK.

The walls of the whole, partially orthogonal, follow the axis of the enclosure of Nectanebo north. An alley separates this last structure of the building to the south. One enters the house by a straight corridor from the alley, and the corridor leads to a central room where the kitchen activities are concentrated. This centerpiece then serves all the surrounding rooms, some of them blocked later after being used as dump areas. Traces of plaster were observed on walls in the rooms located south of the kitchen. To the east, excavations have shown this year the presence of an elongated north-south room, kind of vast storeroom, in which were found numerous silos, despite the deep late pits.



The storerooms area. © CNRS-CFEETK/É. Saubestre.

One of this season the main results is the observation of the dimensions of this architectural unity excavated for two years, which appears as an out-sized house. The logical architectural plan of the structure is emphasized by the existence of a common wall (MR8321) which marks the limit of its extension to the south. With a length of 27.50 m by 20 m – i.e. an area of 550 sq m - it appears as a set of domestic rooms flanked by several economic areas. It is quite unusual in the urban landscape during this late period. It should, however, be noted that some doubt persists regarding the association we make between the rooms excavated last year to the west and economic areas to the east since no threshold connects these two areas. We hope that the continuation of the excavations will answer this question.



The sundial found during the excavation. © CNRS-CFEETK/É. Saubestre.

At the foot of a masonry structure was uncovered a block of hard limestone, originally a sundial. Its form is that of a rectangle with an approximate semicircle top resulting from a rather rough cut. This rough cut is in great contrast with the two flat surfaces and the other three sides of the block. The incisions on both surfaces are themselves quite finely incised. As expected, 12 segments are drawn in a semicircle. This block was not used as a sundial in the archaeological context where it was found. It is here suggested that the sundial was reused maybe as a support and was found *in situ* in its secondary context of use.



The support for jars during excavation. © CNRS-CFEETK.

The discovery, during this season, of a support for jars bearing a decoration of both a Christian cross and a sun disk flanked by two uraei seems to testify in favor of a Christian occupation. The combination of a Christian cross and pagan signs should not surprise, the resilience of these symbols everywhere in the urban landscape - and now detached from any religious aspect - became decorative signs. Although this association may also be seen as a symbol of religious transition. The transition to Christianity was not done in the form of a wave of rapid and complete conversion. Without entering here into the complex problem of conversion to Christianity in Egypt, it should be noted that the fourth and fifth centuries precisely match a transition period during which the remains of the Egyptian religion persisted, giving way to Christianity in a molten whose chronology is difficult to define. Syncretism and tolerance towards the pagan signs, the combination of a Christian cross and a solar disc reflects undoubtedly one of the most important phase of religious evolution during Egyptian history.

Conclusion

After seven seasons of archaeological research conducted in the temple of Ptah and its southern area, the main objectives set at the beginning of the project have been achieved.

Firstly, the limits of the temple precinct in the Ptolemaic period has been determined thanks to the clearance of the extension of the enclosure to the east. After having followed the mudbrick masonry south of the monument, its return to the east then to north towards the enclosure of Nectanebo I was unearthed during the campaign 2016. This significant result for the study of the monument, which is soon to be

confirmed by further excavations, allows to accurately assess the exact extent of religious precinct. During this clearing appeared south of the small Gate C' a space that it would be tempting to identify as a chapel or a storeroom and which will deserve future investigations.

Secondly, the age of the first temple and the diachronic evolution of the sector have been revealed thanks to the opening of a large stratigraphic sounding (12x12 m). A series of domestic constructions still under study predate the religious structures. The plan of the ancient mudbrick building lying under the edifice of Thutmose III, supposedly a temple according to the Cairo stela, was completed during the fieldwork in 2016. In addition, the deep sounding provided the opportunity to clarify the superposition of internal enclosures south of the sanctuary, allowing us to get a clearer understanding of the sequencing of neighboring mudbrick and stone structures.

Thirdly, the last occupation of the area is now being analyzed in the east of the temple of Ptah where extensive excavation by simple surface clearing revealed many mudbrick remains. During this search, an imposing Byzantine settlement dated to the late fourth - early fifth century AD delivered several artifacts reflecting the Christian occupation of the site, but also reflecting a gradual transition with the pagan rites of the previous period.

This fieldwork has given the opportunity to develop ongoing and intensive training for two inspectors of the Ministry of Antiquities of Egypt from 2014 to 2016.

Books in preparation

- G. Charloux, Chr. Thiers, *Le temple de Ptah à Karnak III. La favissa*, 2017-2018
- B. Durand, R. David (under the supervision of Chr. Thiers and G. Charloux), *Le temple de Ptah à Karnak IV. L'occupation byzantine*, 2018-2019
- P. Zignani, *Le temple de Ptah à Karnak V. L'architecture*, 2018-2019
- G. Charloux, Chr. Thiers, with the collaboration of S. Biston-Moulin, S. Marchand, St. Boulet, J. Roberson, R. Angevin, R. David, B. Durand, H. Monchot, Ch. Bouchaud, T. Herbich, M. Abady, A. Nasseh, *Le temple de Ptah à Karnak VI. Résultats des fouilles (2009-2017)*, 2018-2019
- S. Biston-Moulin, Chr. Thiers, *Le temple de Ptah à Karnak VII. Traduction et analyses historiques*, 2018-2019

Ceramological studies from the Third Intermediate Period to the Late Period levels (St. Boulet, LabEx Archimede-CFEETK)

The ceramological studies related to the archaeological levels of the Third Intermediate Period and the Late Period¹⁰ consisted, at first, in analyzing the ceramics testimonies coming from the excavations made by G. Charloux in the area of the Ptah Temple. Despite a small quantity of material and the high fragmentation, these sherds bring important typological information on the Theban pottery industry, apart from the dating of the excavated archaeological contexts.

¹⁰ Ceramological studies in the area of the Ptah temple are divided between several ceramologists according to the chronological phases. The layers dated from the Middle- to the New Kingdom are studied by S. Marchand (IFAO). The ceramic sets dated from the Third Intermediate Period to the Late Period are analyzed by St. Boulet and C. Defernez (CNRS). Finally, the study of the material coming from the levels dated to the Ptolemaic and Byzantine Period is made by R. David (CFEETK).

Several ceramological phases have been distinguished in the sector 6 located in the south of the Ptah Temple. The first one corresponds to the level of the end of the Late Period and the Ptolemaic Period (US 6351, 6353, 6359, 6345, 6341, 6340). The collected pottery in these layers is heterogeneous, and the *terminus post quem* can be associated with the Ptolemaic Period because of the presence of fine Nile clay sherds, a specific criterion of this period, some Marl clay sherds, corresponding to *Late M1* and some testimonies of Egyptian amphora.

The second phase stands for the beginning of the Late Period, more particularly the Nubian occupation in the area of the Ptah Temple¹¹. Some layers, including US 6361, 6363 and 6364, comprise a majority of fragments belonging to the 25th Dynasty. Jars with everted rim (fig. 1.a), with triangular rim (fig. 1.b), with a short neck and a rim marked by a groove (fig. 1.c), with a S-profiled rim (fig. 1.d) and some carinated cups (fig. 1.e) are to be observed among Marl clay production (M1¹²). Sherds of jars with a short neck and bulging rim with white bands on the outer surface are also attested (fig. 1.f). Finally, among the oasian production, some testimonies of Dakhleh Oases have been discovered including fragments of cylindrical bottles (fig. 1.g) and elements from the Bahariya Oases, e.g. small lids (fig. 1.h-i) and sherd of kegs.

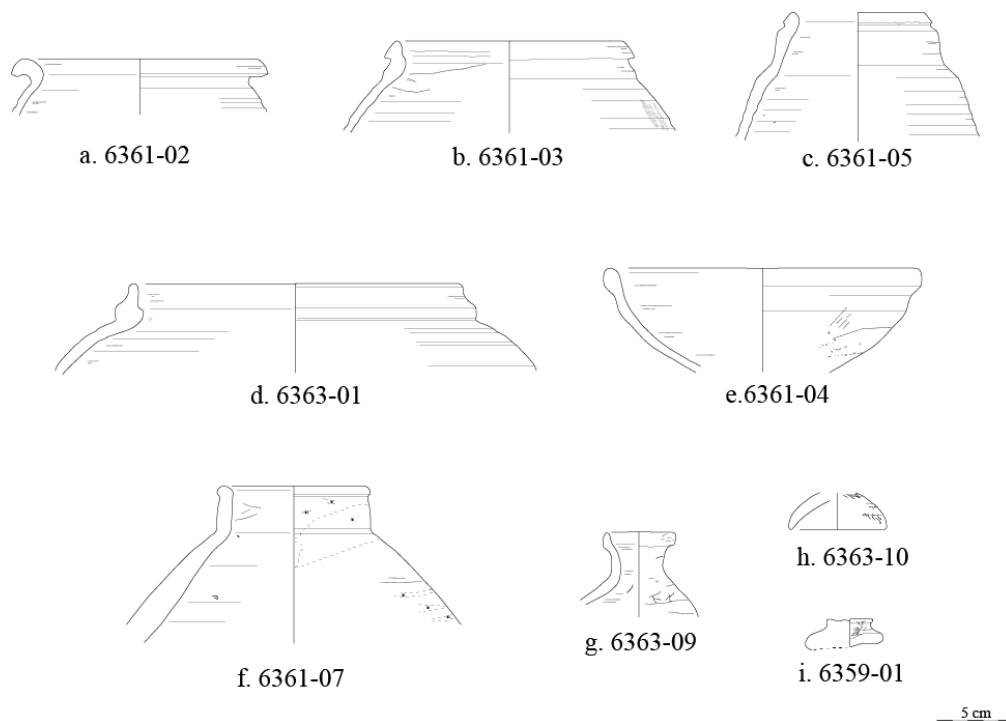

Fig. 1: ceramic production of the Nubian period from the sector 6 (Drawings: St. Boulet. © CNRS-CFEETK).

¹¹ N. LICITRA, Chr. THIERS, P. ZIGNANI, “A Major Development Project of the Northern Area of the Amun-Re Precinct at Karnak during the Reign of Shabako”, in E. Pischikova, J. Budka, K. Griffin K. (eds.), *Thebes in the First Millennium BC*, Cambridge, 2014, p. 549-563.

¹² Corresponding to the BE 1 identified by C. Derfernez (L. COULON, C. DEFERNEZ, “La chapelle d’Osiris Ounnefer Neb-Djefauou à Karnak. Rapport préliminaire des fouilles et travaux 2000-2004”, *BIFAO* 104, 2004, p. 177) and the Marl A4 variant 2 of D. Aston (D.A. ASTON, *Elephantine XIX: Pottery from the Late New Kingdom to the Early Ptolemaic Period*, *ArchVer* 95, 1999, p. 4).

Furthermore, these levels include some sherds dating back to the late ramesside period until the beginning of the Third Intermediate Period. They are mainly attested in US 6364 and 6366. Some jars with bulging neck in Marl clay (fig. 2.a), some large jars in Nile clay (fig. 2.b) and some large carinated cups in Marl clay with black-painted decoration (fig. 2.c-d) have been discovered¹³, although they were not numerous and very fragmented.

Punctual investigations were carried out in the sector 5. Diagnostic sherds are not so many, but some elements bring to the Ptolemaic period (US 5050, 5048, 5044, 5046), from the 25th to the beginning of the 26th Dynasty (US 5051, 5049, 5040, 5042) and, for the last level, to the New Kingdom (US 5053, 5054).

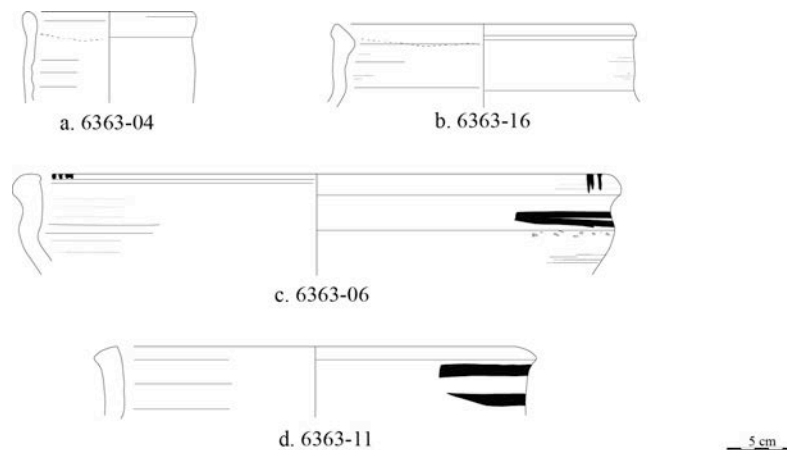

Fig. 2: ceramic production from the late ramesside period to the beginning of the Third Intermediate Period from the sector 6 (Drawings: St. Boulet © CNRS-CFEETK).

The second aim of the ceramological analysis was to complete and to finish the study of ceramic sets discovered during previous archaeological investigations conducted by L. Amami in 2011-2012 in the area of the Ptah Temple. Among these sets, a majority came from layers located in the southern door in the south of Ptah Temple. The study of these Nubian period sets was started in 2011 by St. Boulet and C. Defernez¹⁴ (corresponding to the sounding SD 07, SD 09, SD 11). Jars with convex rim (fig. 3.a), thick rim (fig. 3.b), triangular rim (fig. 3c-e), flasks (fig. 3.f), carinated cups (fig. 3.g) and large cups (fig. 3.h) are attested¹⁵ in ceramic data in Marl clay *M1*.

In January 2015, G. Charloix led excavations in the courtyard of the 10th pylon¹⁶. In the several layers of the end of the Late Period and Ptolemaic Period that were excavated (US 188033, 188029, 188028, 188025, 188021, 188020), sherds in fine Nile clay, specific of the Ptolemaic period and in Marl Clay *Late M1* were found. The diagnostic fragments include beakers with flattened base, cut with a string, in Nile

¹³ Finally, the underlying levels included Pottery production from the Middle to New Kingdom and will be studied by S. Marchand (IFAO) during the next missions.

¹⁴ St. BOULET, C. DEFERNEZ, *Karnak. Temple de Ptah (2011-2012). Examen céramologique*, 2013, p. 1-6; online report: <http://www.cfeetk.cnrs.fr/index.php?page=rapport-2012-ptah-ceramique>

¹⁵ Other sets coming from the sectors 1, 4, 8 and 10 have been studied and complete the chronological and ceramological data from the previous investigations in the area of the Ptah Temple.

¹⁶ Cf. *CFEETK, Activity report 2015*, p. 72-76.

clay (fig. 4.a-b), bowls and carinated cups in Nile clay (fig. 4.c-d), large vase with everted rim in fine Nile clay (fig. 4.f) and a small Bes vessel in Nile clay (fig. 4.g).¹⁷

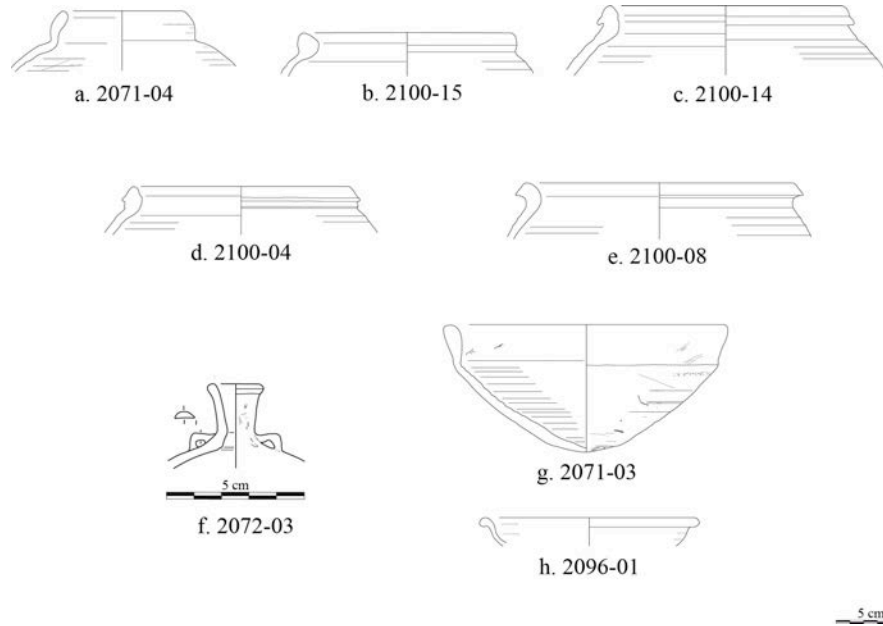

Fig. 3. ceramic production from the Nubian period, coming from the sector 2 (Drawings: St. Boulet © CNRS-CFEETK).

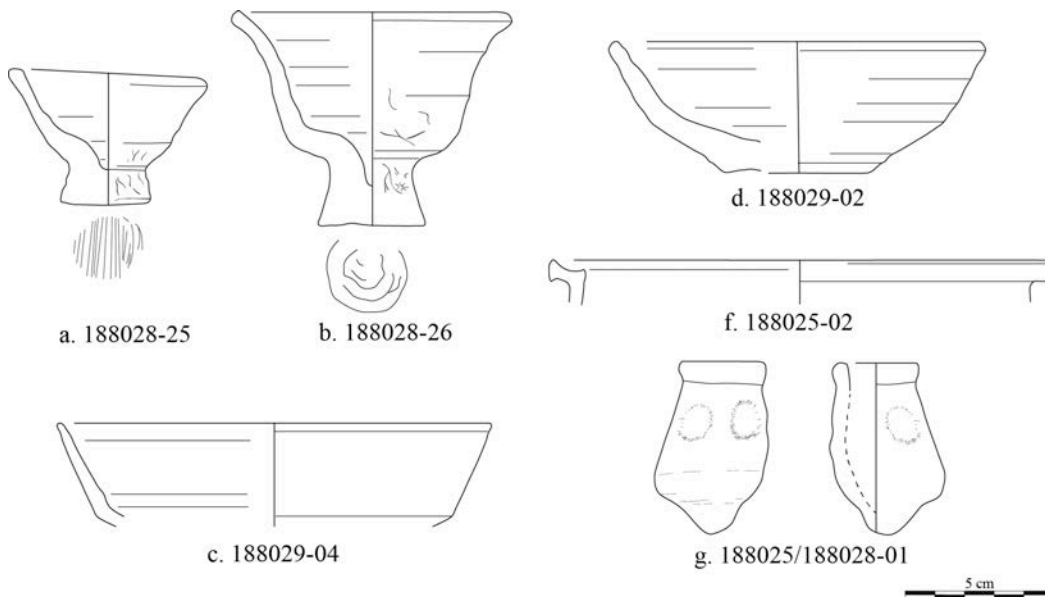

Fig. 4. Ceramic production from the end of the Late Period to the Ptolemaic period, coming from the courtyard of the 10th Pylon. (Drawings: St. Boulet © CNRS-CFEETK).

¹⁷ These sets are heterogeneous and the recent testimonies are associated with elements dated from the Middle Kingdom to the Late Period.

The last objective of these ceramological studies was to integrate the information collected on the field in a global work about the developments of the ceramic production in the Theban area from the Third Intermediate Period to the Late Period. This piece was written in the framework of a postdoctoral project of one year, financed by the LabEx Archimede and entitled « *Contribution des études céramologiques à l'histoire politique et économique à Thèbes sous la 25^e dynastie* ». ¹⁸

¹⁸ This project is supported by LabEx ARCHIMEDE from “Investissement d’Avenir” programme ANR-11-LABX-0032-01.

1.3. CULTS AND PLACES OF WORSHIP

1.3.1. The Monuments of Amenhotep I (J.-Fr. Carlotti, L. Gabolde)²⁰

The mission took place from February 19th to March 12th, and its main objective was to check the vectorized drawings for the first volume of the *Monuments of Amenhotep I at Karnak*, volume devoted to the calcite bark-shrine of Amenhotep I and Thutmosis I rebuilt in the open air museum.

This volume does indeed comprise a total of 81 plates, including 25 fac-similes drawings of the complete and the detailed decoration of the monument.

The 25 fac-similes require a heavy task of checking, correcting and drawing modifications. This phase appeared to be much more time-consuming than primarily expected.

On the 25 fac-similes drawing plates, 19 have been checked, and corrected, and 2 are in process; 4 remain to do.

The first volume of the series, dealing with the calcite chapel, has been accepted by the editorial committee – to the IFAO in 2012. A grant from the Labex Archimède of the University Paul Valéry – Montpellier 3 has been obtained in 2014.

The text volume has been checked and submitted to few modifications and additions. When the control process of the plates will be finished, the volume will be sent to the Ifao for DTP and printing. This process lasts generally one to two years.

The task of checking and correcting the plates volume has been extremely time-consuming and thus didn't allow us this year to work of the other monuments of Amenhotep I.

²⁰ Acknowledgements: Dr. Mohamed Abdel Aziz, General Director of the Temples of Karnak, and Abder-Raheem Khazafi, Director of the Temples of Karnak, have welcomed us in the name of the Ministry of Antiquities and favoured our work on the spot with a very kind attention for which we are very grateful. Inspector Siham Abd el Ghafar has followed our researches. The CFEETK, represented by the director of the USR 3172 of the CNRS, Christophe Thiers and by its administrator, Veronique Puelle, provided us with an efficient logistical help, and its documentalist, Sébastien Biston-Moulin, opened to us the ressources of the library and of the archive.

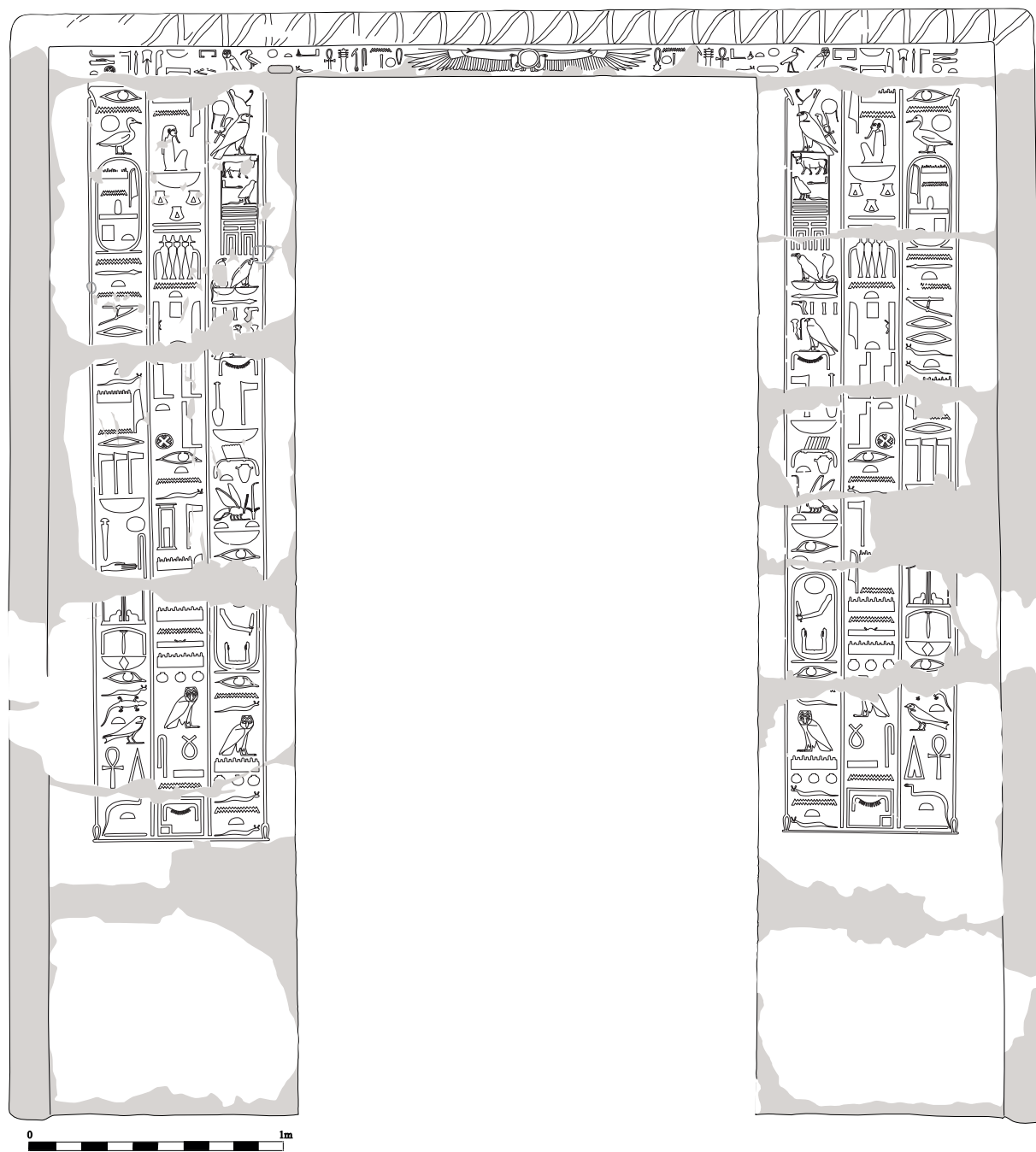

Fac-simile of the façade of Amenhotep I – Thoutmosis I's calcite chapel at Karnak.
(pl. XX of the forthcoming publication)

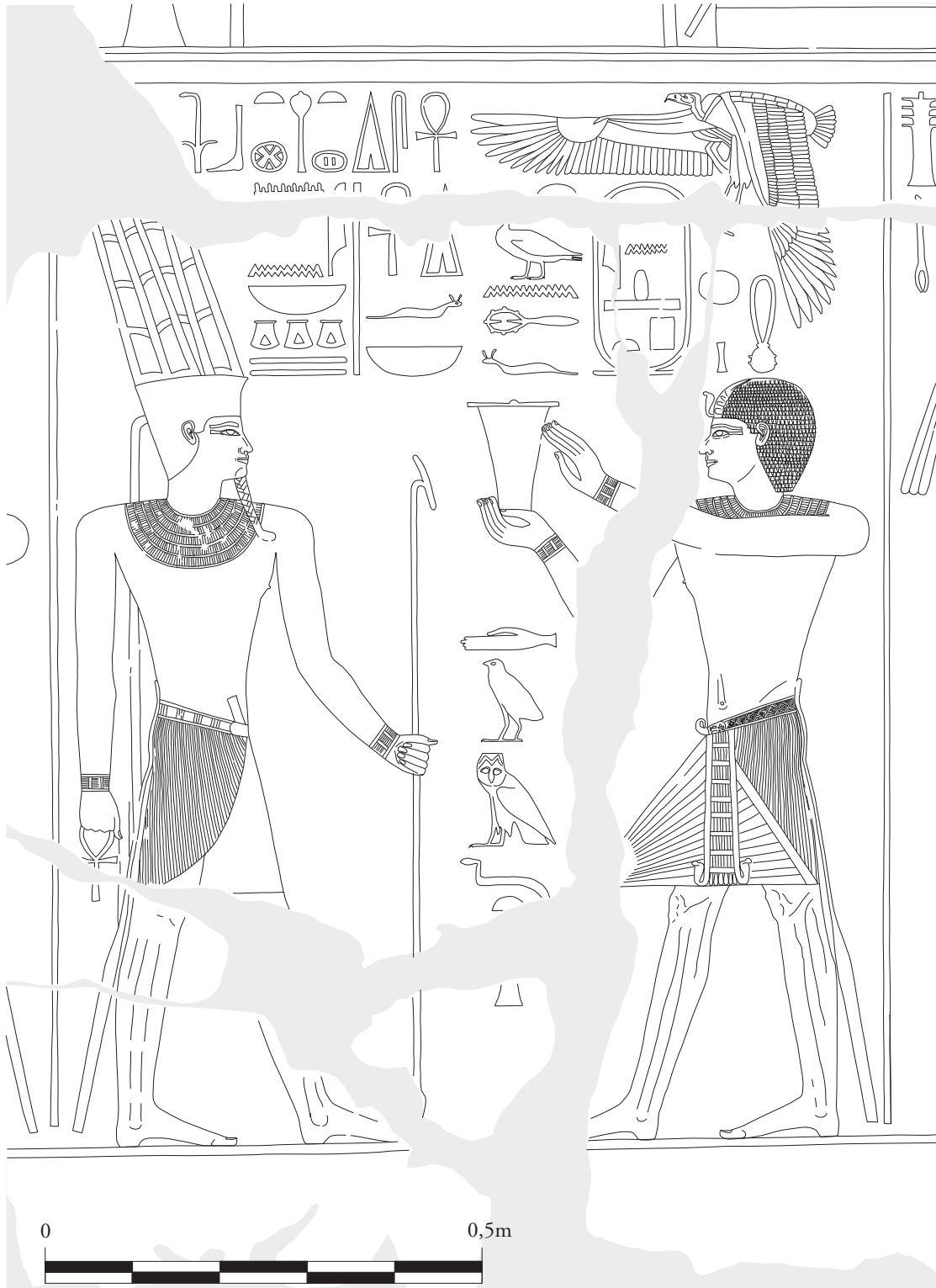

Fac-simile of scene 2, inner side, north wall, lower register of Amenhotep I – Thutmose I's calcite chapel at Karnak. (pl. XLII of the forthcoming publication).

1.3.2. The Osirian Sanctuaries (L. Coulon, C. Giorgi)

The fifteenth campaign of excavation and restoration of the chapels of Osiris to the north of the Great Hypostyle Hall, combined with fieldwork on the chapel of Osiris Ptah Neb-anekh and the chapel of Osiris Neb-ânkh-di-heb-sed, was undertaken with the support of the CFEETK, the French Institute in Cairo (IFAO), INRAP, EA 4519 (EPHE), HiSoMA (Maison de l’Orient et de la Méditerranée, Lyon), Orient & Méditerranée - Mondes pharaoniques (Paris-Sorbonne), between February, 1st and March, 2nd 2016.²¹

1. Excavations of the chapel of Osiris Wennefer Neb Djefau (C. Giorgi)

This season, several soundings were undertaken inside or next to the chapel of Osiris Wennefer Neb Djefau, with a special focus on the northern part of the pylon and the area between the chapel and the alley of Ptah. Five sectors were excavated this year, which allowed to refine the data collected during the previous seasons, concerning the building in the 26th Dynasty, but also for later occupations (Ptolemaic and Roman period).

²¹ The members of the team were Laurent Coulon (Egyptologist, EPHE, director of the mission), Cyril Giorgi (archaeologist, INRAP, co-director of the mission), Catherine Defernez (ceramologist, University of Paris IV-CNRS), Frédéric Payraudeau (Egyptologist, University of Paris IV), Stéphanie Boulet (ceramologist, Postdoctoral Fellow LabEx-ARCHIMEDE - Univ. Montpellier 3 - CFEETK), Laurent Vallières (topographer, INRAP), Anna Guillou (archaeologist and Egyptologist), Alexandre Rabot (archaeologist, HiSoMA, University of Lyon), Thomas Faucher (archaeologist, numismat, CNRS), Aleksandra Hallmann (Egyptologist, Polish Academy of Science, Institute of Mediterranean and Oriental Cultures, Warsaw / Oriental Institute Chicago), Hassan el-Amir (conservator, IFAO), Sylvie Marchand (ceramologist, IFAO) and Khaled Zaza (artist, IFAO). The objects were photographed by Jessie Maucor (USR 3172/Cfeetk) and her team. The restoration of the naos was undertaken by Salah Salem Sayed (conservator, MoA Karnak), under the supervision of Mr. Abd Al-Nasser (head of restoration service at Karnak).

Three inspectors of the Supreme Council have attended the training session which took place between February 8th and 15th, 2016: Mr Walid ElSayed Abd El-Raheem, Mr Ibrahim Mustafa Ibrahim EL-Sayed and Mrs Aya Ismail EL-Sayed Mohammed. Mrs Hannah Sonbol (PhD student, DAIK) has attended a training session in epigraphy from January 30th to February 20th, 2016. Mr. Mahmoud Mohamed Saad ed-Din, Mr. Baa Abou Majed Amin (excavations) and Mr. Wahid Yusef (Evergete storeroom) were representing the Ministry of Antiquities under the supervision of Mr. Mohamed Abdel Aziz, Mr. Amin Amar, Mr. Abder Rahim Kazafy, Mrs. Mona Fathi and Mr. Abd Al-Sattar Badri.

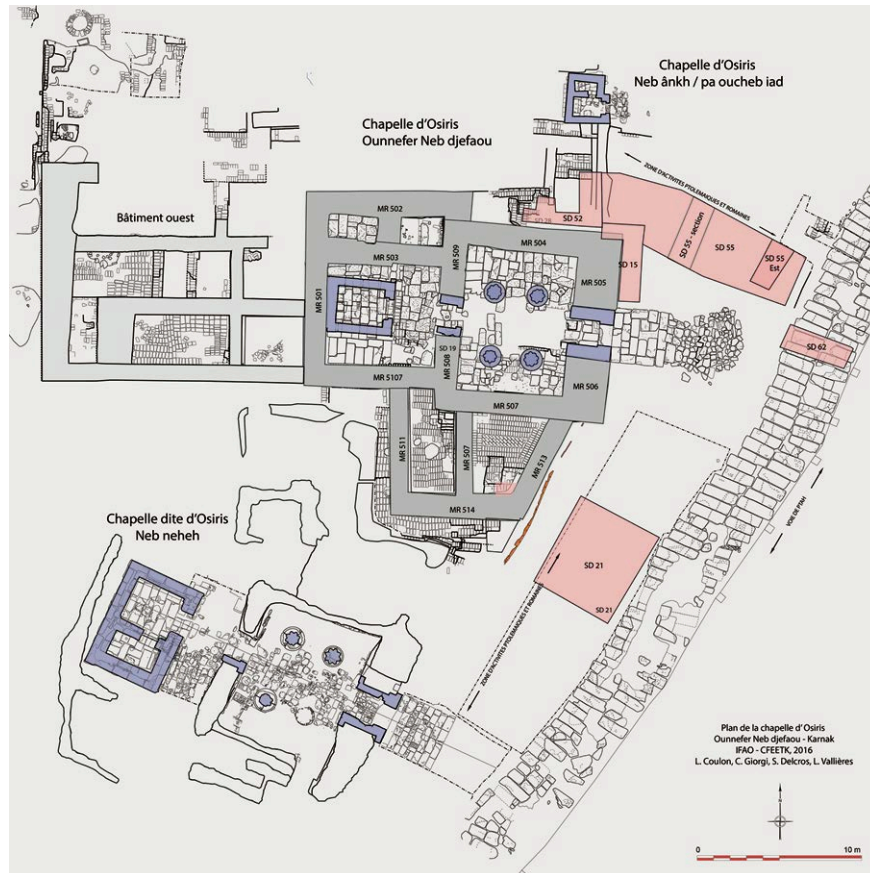

Plan of the chapel of Osiris Wennefer Neb djefau and the sectors excavated on the season 2016.

- *The connection with the chapel of Osiris Ptah Neb ankh / pa wesheb iad*

During this season, we undertook several soundings to distinguish 26th Dynasty and Ptolemaic phases of constructions at the north-eastern corner of the chapel of Osiris Wennefer Neb djefau. In many cases the partition mudbrick walls and enclosure walls have been restructured several times, which radically changed the aspect of the initial building. As a reminder, in the north-eastern corner, into the walls MR 504 and MR 505, a ceramic deposit had been previously found, locked inside a reused blocks arrangement, covered by a mudbrick wall dated from the Ptolemaic period. In the same area (MR 504, MR 517 and 518), we found this year another ceramic deposit, settled this time under a mudbrick wall considered so far as part of the chapel. This new deposit had been installed into a pit and included an intact amphora covered by another intact bowl. The study of the different artifacts enabled us to reconsider the datation of this mudbrick wall (4th and 3rd cent. BC), and to modify the plan of the chapel in its initial stage of construction.

Moreover, we established that the modification of the enclosure of the chapel during the first part of the Ptolemaic period was intrinsically linked to a larger project including not only the chapel of Osiris Wennefer Neb Djefau, but also the 25th Dynasty chapel of Osiris Ptah Neb ankh / pa wesheb iad. After the abandon of the Saite chapel, a Ptolemaic mudbrick wall was included in the masonry of the northern part of the pylon and connected to the enclosure wall of the chapel of the Kushite chapel.



Ceramic deposit located on the north part of the chapel into the wall MR 504, MR 517 and MR 518. © C. Giorgi.

• *The northern part of the entrance pylon*



View of the northern part of the pylon (MR 505) with several Ptolemaic mudbrick walls connected to it. © C. Giorgi.

On each side of the northern part of the pylon (MR 505), inside and outside the chapel, we found different phases of restorations and re-occupations which destroyed a great part of this one. Inside the chapel we discovered several ceramic deposits and many spaces restructured and reconstructed, included in a larger project. Outside the chapel, a large platform is composed of mud, floor levels of mud bricks, and some walls forming small spaces. This area dated from the 3rd and 2nd cent. BC was directly

connected with the north-eastern corner of the pylon, making it difficult to understand its original architecture. During this campaign, a new excavation allowed us to find a part of the corner of the northern part of the pylon and to define his foundation. Unfortunately, the corner of the pylon had been completely reconstructed during the Ptolemaic period, and rebuilt twice. This point of connection between the different phases of occupation, reoccupation and reconstruction, located at the corner of the pylon, will be studied again next season, to better understand the complex architectural phasing, in this area (between the 26th Dynasty and the Roman period).

- *The North-eastern area, outside the chapel*

The aforementioned large Ptolemaic platform has been studied further to establish a more precise chronological sequence. Thus, we undertook a perpendicular section in this platform, to understand and record the different stages of construction. The reading of the stratigraphic layers allowed us to identify three different levels of Ptolemaic construction under the most recent levels (dated from 1st and 2nd cent AD).



View of the northern part of the pylon and Ptolemaic platform. © C. Giorgi.

Furthermore, we could determine that these Ptolemaic constructions (mainly mudbrick walls) cut a previous layer of sandstone blocks and chips of sandstone (considered as a layer related to a phase following the destruction of the chapel), and other ones on which are based the foundation of the first door and the pylon of the chapel of Osiris Wennefer Neb Djefau.



View of the reused sandstone blocks, located in the middle of the Ptolemaic platform. © C. Giorgi.

A few meters from the perpendicular section, a surface cleaning allowed us to find many reused sandstone blocks forming what appears to be a stairway. The dimensions of the blocks identified correspond to a set of blocks already discovered last year, and perhaps associated with secondary doorposts of the chapel of Osiris Wennefer Neb Djefau. The excavation could not be completed this season and the blocks were kept in situ.



Domestic levels of the Roman period. © C. Giorgi.

To understand the links between this platform and the alley of Ptah, we started a short survey of its eastern part. Quickly, we found a well-preserved domestic space, in which more than a dozen intact vases were found; they have been studied by S. Marchand. Within this level many additional objects have been identified, such as buffers, sharpeners, figurines, fragments of statues, gold leaf, fragments of coins. A large jar (VP 55209), found intact, was installed between two walls in a mudbrick layer and then blocked by another complete ceramic (VP 55210). Inside the jar, we found three additional complete ceramics, a

Greek ostrakon (identified by H. Cuvigny as a tax receipt issued by tax collectors under the reign of Antonin the Pious) and two coins probably of the 1st cent AD. This new ensemble is to be related to the one identified in 2015, in which many complete miniature size ceramics (dated from 1st and 2nd cent AD) were also found.

- *The alley of Ptah*



The sector of the paved alley under excavation. © C. Giorgi.

During the previous season of excavation, we resumed the study of the alley leading to the temple of Ptah by making a cleaning of a little part of the sandstone pavement in order to record each component and to choose the best place to make a cut section. This four-meter-wide and one-hundred-fifty-meter-long alley, in a very poor state of conservation, is formed of two rows of sandstone blocks posed transversely. The thickness of the blocks is variable (between 15 and 30 cm), and many of them are reused blocks. During this season, we removed four blocks of the pavement to understand its foundation and all the preparatory levels which were necessary to build it. The excavation was the study case for the students of the field school. Under the pavement, over twelve stratigraphic layers have been identified, but only four are shown to be associated. It was possible to highlight the levels of preparation and installation of the paved path (where we found Ptolemaic and Saite sherds), and previous preparatory levels, suggesting the presence of a previous path or alley. Moreover, the presence of clearly identified levels of the Third intermediate period and/or Ramesside period and a mudbrick wall with a north-south orientation, could suggest the presence of an older axis, with a completely different direction, which could be possibly connected to the gate of Ramesses III. Only the excavation of several areas in the alley will allow to understand this construction of more than 150 meters long.



View of cut section on the alley of Ptah, and the mudbrick wall. © C. Giorgi.

- *The Ptolemaic and Roman activity area to the south-east of the chapel*

Following the work undertaken in 2007-2008 and 2013-2014, additional excavations were undertaken by Thomas Faucher next to the area where the metal and copper workshop was found, between the south-eastern precinct wall of the chapel and the alley of Ptah. The question this year consisted less in finding areas of metal working than understanding the process of reoccupation of the chapel after its destruction and the settlement of buildings outside the surrounding walls at the Ptolemaic period. The soundings focused mainly on the southern part of the place (SD 21), on both sides of an elongated wall that almost cross the Ptolemaic structures.

We saw in 2013 that the high wall was built on a thick layer of sand that was covering a layer of chips of sandstone found almost everywhere in front of the chapel. On the western side of this wall, a series of construction took place, and the first occupation of the room using this wall was recognized and excavated. It consists in a thick layer of mud floor on the top of which we recognized an occupation layer. In this room, we found a large structure made of mud, which was a sort of storage. This structure was filled up with a large abandonment layer. In this structure, we found three complete *unguentaria* and a decorated cauldron handle. These ceramics date back from the 3th cent. BC and therefore give information on the building of the zone.

On the eastern side of the long wall, most of the remains have been dug out by previous attempts to uncover the pavement of the way of Ptah. Fortunately, a small area was conserved well enough to show a Roman phase of occupation. A careful cleaning allowed us to bring to light the installation, inside the Ptolemaic mudbrick structures, of small, badly preserved, vaulted rooms, maybe dedicated to the storage or the selling of goods, along the pathway. These data complete those from 2014 excavations, as a very similar structure had been found at that time in the northern part of the area. Underneath these Roman levels, we found a Ptolemaic layer of occupation, including the remains of a large room, of which we have only three walls (the other one being lost). There were two phases of floor building, the first layer of mud being separated from the second one by a thick layer of mud. In the northern part, there was a large pit that

goes deep down through the different mudbrick and sand layers. Inside it were found late Roman ceramics.



Vaulted room on the eastern part of SD21. © Th. Faucher.

2. Ceramological Studies (St. Boulet, C. Defernez, S. Marchand)

The ceramological research conducted on the material from the Third Intermediate Period to the Late Period had several objectives: the first one was the analysis of sherds coming from the field during this season. For instance, to the north of the hypostyle hall of the chapel (SD 52), a complete amphora was found in the filling of a pit (see above). This jar shows the characteristics of the Aegean productions (Eastern part of Ionia) and can be ascribed to the second part of the 4th century. As it was found in early Ptolemaic occupation levels, studied by S. Marchand, this container had probably been reused in this context. The pit in which the amphora was placed recuts levels which predate the construction of the chapel; some ceramic sherds datable from the Third Intermediate Period and the 25th dynasty were identified.

Another important part of the work was focused on ceramic assemblages coming from previous excavations. Pottery found between 2000 and 2006 in the building located behind the Osirian chapel has been analyzed by Catherine Defernez. The rigorous exam of these contexts brings important perspectives on the development of the ceramic industry in the Theban area and trade between the Mediterranean Basin and the Upper Egypt, from the 5th to the end of the 4th century BC.

In addition, in the framework of a postdoctoral project entitled “Contribution of the ceramic studies to the Theban political and economic history during the 25th Dynasty” funded by the LabEx ARCHIMEDE (IA-ANR-11-LABX-0032-01), the research on the ceramic productions of the Third Intermediate Period and 25th Dynasty have been continued by St. Boulet all through the year. The study of the assemblages found in soundings SD 03, SD 31, SD 33 and SD 42 between 2010 and 2015 has allowed her to complete and refine the chronological sequences of the local ceramic productions for these periods. This project is inserted in a broader research which aims at understanding the technological, technical and morphological evolutions of the Theban ceramic production in the middle of the 8th century BC.

Thanks to the rigorous archaeological excavations and ceramological analysis at the site of the chapel of Osiris Wennefer Neb djefau, we are now able to undertake a precise chrono-typological study of the local and imported ceramic productions between the end of the Ramesside Period and the end of the Late Period. This far-reaching project also aims at studying the international and inter-regional exchanges during these periods. Finally, the data collected by S. Marchand allow to complete this corpus for the later periods (Graeco-roman and Byzantine).

3. Epigraphic and iconographical studies (L. Coulon, A. Guillou, A. Hallmann)

After the last checking made this year by A. Guillou, A. Hallmann, D. Devauchelle and Gh. Widmer and L. Coulon, the plates of the publication of the chapel of Osiris Wennefer Neb Djefau are now ready for publication. Some minor complements were added, including a joint between a doorjamb found among the scattered block discovered in the site at the beginning of our work in 1999 and a fragment found during the recent excavations, in a Ptolemaic layer.

A photogrammetric recording of the reliefs of the neighbouring so-called chapel of Osiris Neb neheh was undertaken to improve the accuracy of the drawings. Aleksandra Hallmann started the study of the iconography of the chapel and has recorded many hitherto unnoticed traces of colours (mostly blue and yellow).

The iconographic study led by A. Hallmann continued also in the chapel of Osiris Ptah Neb-anekh. This season, a special attention was paid to the distribution of colours and their preservation in order to supplement the visual analysis by archaeometry in the future. The goal of this research is to examine the different stages of chapel decoration from the preparation of the wall to the last stage of painting's application, as well as techniques used by the artists.

4. The Chapel of Osiris Neb-anekh di-heb-sed (A. Hallmann)

The chapel of Osiris Neb-anekh di-heb-sed, situated in Montu's precinct at Karnak North and inscribed with the names of Nitocris and Psammetichus I, was published by L.A. Christophe in *Karnak Nord* III, but its reliefs have so far not been properly recorded and photographed. To make visible the entire preserved decoration and record it, it was necessary to remove a significant amount of debris that surrounded the chapel and to restore some badly weathered parts of the chapel. A photographic and photogrammetric survey of the building was made by A. Hallmann and L. Vallières.



Central part of the chapel of Osiris Neb-ânkh-di-heb-sed after cleaning. © C. Giorgi.

Bibliography

- St. Boulet, “Étude céramologique préliminaire des campagnes de fouille de la chapelle d'Osiris Ounnefer Neb-Djefaou 2013-2014”, *Cahiers de Karnak* 15, 2015, p. 63-79.
- St. Boulet, “Les productions oasiennes des 25^e et 26^e dynasties de la chapelle d’Osiris Ounnefer Neb-Djefaou”, in S. Marchand (ed.), *Atlas des céramiques d’Égypte vol. 1 : La céramique du désert Occidental de la fin du Néolithique à l’époque moderne. La Marmarique, le Wadi Natrun et les oasis de Bahariya, Dakhla et Kharga*, CCE 11, forthcoming.
- St. Boulet, “La chapelle d’Osiris Ounnefer Neb-Djefaou à Karnak : nouvelles avancées sur les développements des productions céramiques entre la Troisième Période intermédiaire et la Basse Époque”, *BCE* 26, 2016, p. 213-226.
- St. Boulet, “Les productions céramiques de la Troisième Période intermédiaire : Entre traditions et innovations”, *Égypte Afrique et Orient* 81, 2016, p. 31-38.
- L. Coulon, “Les chapelles osiriennes de Karnak. Aperçu des travaux récents”, *BSFE*, forthcoming.
- L. Coulon, Fr. Payraudeau, “Une princesse saïte à Thèbes sous la XXV^e dynastie ?”, *RdE* 66, 2015, p. 21-31.
- L. Coulon, D. Laisney, “Les édifices des divines adoratrices Nitocris et Ankhnesnéferibrê au nord-ouest des temples de Karnak (secteur de Naga Malgata)”, *Cahiers de Karnak* 15, 2015, p. 81-171.
- C. Defernez, “Investigations récentes et mobilier importé des époques saïte et perse dans le temple d’Amon-Rê à Karnak”, in G. Gorre G., A. Marangou (eds.), *La présence grecque dans la vallée de Thèbes*, Rennes, 2015, p. 45-65.
- S. Marchand, avec une introduction archéologique par Th. Faucher, “La céramique d’un atelier monétaire à Karnak du II^e siècle av. J.-C.”, in G. Gorre, A. Marangou (eds.), *La présence grecque dans la vallée de Thèbes*, Rennes, 2015, p. 101-112.

1.3.3. The bark-shrine of Philipp Arrhidaeus (Chr. Thiers, A. Tillier)²²

The set of the drawings was completed, the final checking has been made in 2016 in the second room.

The inventory of scattered blocks belonging to the chapel continued by a systematic survey of the northern and southern blockyards. After an examination of different kinds of granites made in October-November 2015 by Charlie Labarta, it was possible to associate several loose blocks to the chapel of Philip Arridaeus. They will be included in the final publication in preparation.

1.3.4. The Central sanctuaries of the *Akh-menu* and “Northern Storerooms” (Chr. Thiers, Chr. Leitz, S. Biston-Moulin)²³

This epigraphic and conservation (see below) programme is led in partnership with the University of Tübingen (Prof. Chr. Leitz).

The final checking of the drawings of the “Northern storerooms” were undertaken, in particular to complete the drawings with traces of colors which appeared after the important cleaning and conservation work.

During the campaign in September 2016, the drawings of the sanctuary of Alexander were collated. As in the year before, a scaffolding had to be erected in the sanctuary for the scenes in the upper registers and the ceiling. Further we made a plan of the blocks of the eastern wall to discuss the situation of the different blocks that were used to build the rear wall of the sanctuary on the spot. As it seems, more than two different block types were used to erect this wall at some time in antiquity.

As the restoration of SX 4 was finished in 2015 (see below) making possible to see much more of the original colours, it was necessary to build up the scaffolding again to collate once more the eastern and northern walls of SX 4.

Aside from collating the already drawn eastern wall of JB 1, a scaffold was put up in front of one of the columns of JB 1 to make a test for the drawings of the inscriptions on the columns. We also made a further survey in the rooms for objects that were found and supposed to originally belong to these rooms and therefore are part of our documentation.

²² With Fl. Pirou (LabEx Archimede) and Mamduh Abd el-Ghassul (MoA-CFEETK).

²³ With Fl. Pirou (LabEx Archimede), M. Abd el-Ghassul (MoA-CFEETK), D. Mendel, A. Rickert (univ. Tübingen).

1.4. THE KARNAK PROJECT (S. Biston-Moulin, Chr. Thiers)²⁴

Initiated in January 2013, the Karnak project (CNRS, USR 3172 - CFEETK / UMR 5140, Équipe ENiM - Programme “Investissement d’Avenir” ANR-11-LABX-0032-01 Labex ARCHIMEDE) aims to organize and make available textual documentation from the temples of Karnak.

In 2016, the Karnak project reached 4,000 hieroglyphic inscriptions of the temple of Karnak accessible online with permalink providing access to the full records (hieroglyphic text, photographs, facsimiles, bibliography, etc.).

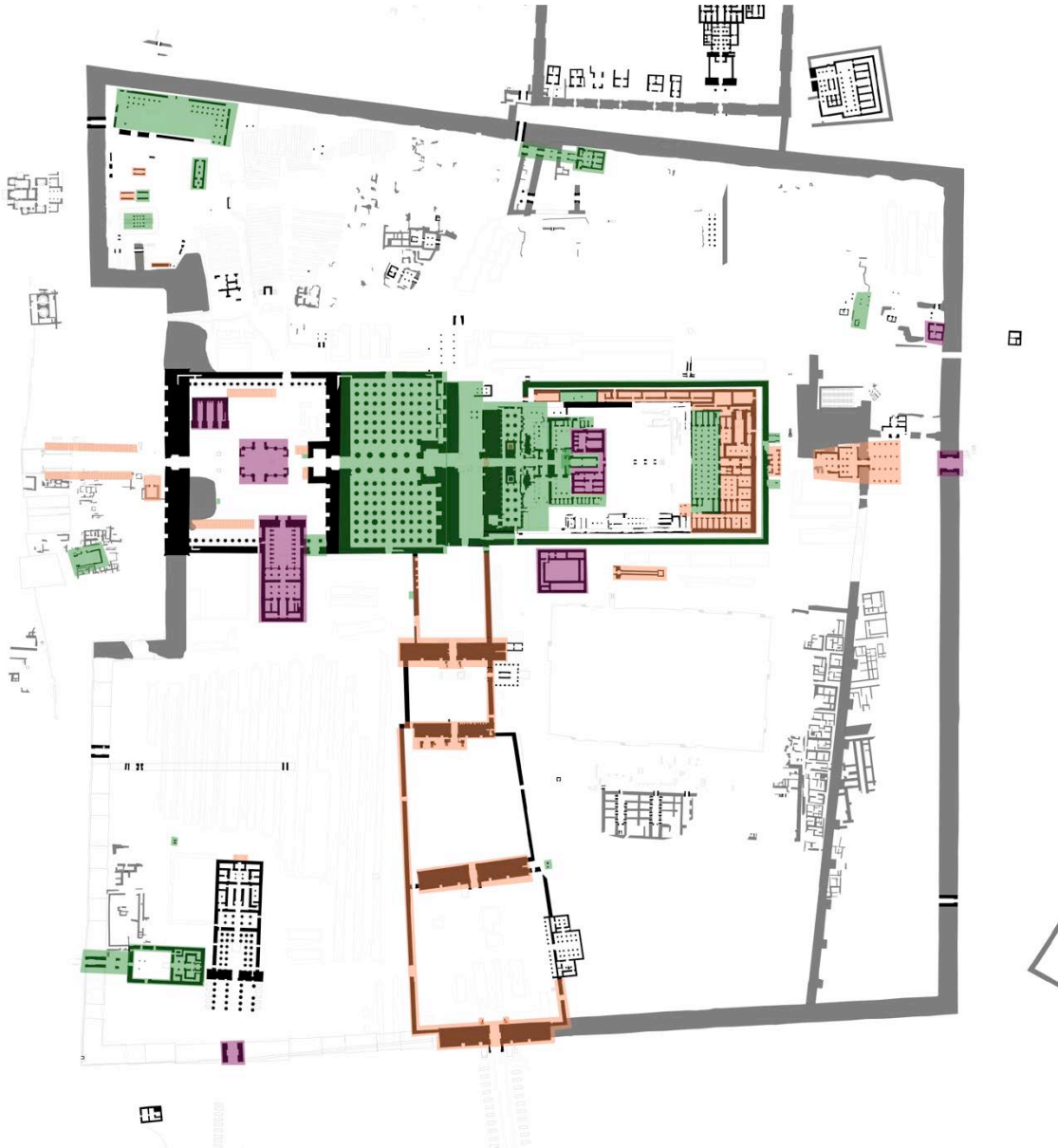

Green: online or partially online; orange: completed in the reviewing process; purple: in progress.

²⁴ <http://www.cfeetk.cnrs.fr/karnak/>, <https://karnak.hypotheses.org/>; with Dr. G. Dembitz, Dr. J. Hourdin, Dr. Ch. Labarta, Fl. Pirou (LabEx Archimede), F. Hamonic, R. Betzeze, S. Cassor-Pfeiffer (CNRS trainees).

The Karnak project is already at this stage one of the largest freely accessible hieroglyphic databases on the internet.

Slightly less than 8,000 hieroglyphic inscriptions are now integrated into the project. These entries are gradually released online after reviewing and approval by the project members.

As the website and all CFEETK projects hosted on servers in the In2p3, the interface of the *Karnak* project (version 0.1.5) has encountered technical difficulties this year since March. Access to some functions had to be temporarily limited. We study the possibilities to resolve these problems as soon as possible.

More than 3,000,000 visitors accessed the online project during its first years of existence.

The work on the Karnak project also allows identifying insufficiency in the photographic documentation kept in the archives of the CFEETK. A programme of photographic survey based on the inventory of the Karnak project was accordingly established with the photographic service of the CFEETK. The orthophotographic technique (AgiSoft PhotoScan software) also allows obtaining within a reasonable time the large number of photographs necessary for the progress of the project and to regularly add online new documents.

The work carried out on the Karnak project in recent years allowed to publish in June 2016 a first version of the Inventory of monuments, objects, scenes and inscriptions of the temples of Karnak. Nearly half a century after the last update published in the Topographical Bibliography of Ancient Egyptian Hieroglyphic Texts, Statues, Reliefs and Paintings that Bertha Porter and Rosalind Moss devoted to the Theban temples, this new inventory of the decoration of the temples of Karnak allows to include the extensive bibliography published since then, including many archaeological and epigraphic projects conducted by the Franco-Egyptian Center for the Study of the Temples of Karnak since its creation in 1967 (15 volumes of the *Cahiers de Karnak*, over twenty monographs and hundreds of articles).

The first versions of this work are released with a version date, in Pdf format from the websites of the French-Egyptian Center for the Study of the Temples of Karnak (MoA/CNRS USR 3172) and the team of Egyptology of the University of Montpellier (CNRS UMR 5140). The inventory has already been downloaded more than 4,000 times.

A series of papers related to the *Karnak* project has also been published under the title *Karnak Varia* in the last volume of *Cahiers de Karnak* (15), other contributions will be published in the volume 16.

2. RECONSTRUCTION PROGRAMMES (A. Garric)²⁵

2.1. The calcite chapel of Tuthmosis III

The two megaliths have been installed last year at the chapel top. The activity has been focused this year on the finishing work and development of the monument. We realized a sandstone paving of 2 m wide around the perimeter of the two chapels (the chapel of Thutmose III is connected to that of Thutmose IV), over a total area of 120 sq m. It allows an easy and secure traffic of tourists visiting the monument. We reused work slabs that had served for the construction of lifting structures of megaliths, optimizing maximum available materials.

We also carried out few centimetres depressions on concrete foundations allowing the installation of a new floor inside the two chapels (40 sq m). It consists of a reconstituted stone mortar with polishing and joints mimicking an ancient paving of large calcite module.

Some small decorated fragments were replaced on the west façade. The missing parts of the torus mouldings at the four corners of the chapel were restored.

After several colour tests and a concerted choice with the antiquities service, the finish coatings have been made on the chapel walls, thus finalizing a many years long work and allowing the opening to the public.



The chapel of Thutmose III behind the one of Thutmose IV. © CNRS-CFEETK/Chr. Thiers.

A. Garric also made a complete photographic survey of the upper face of the ceiling for 3D modeling and orthophotos, as well as the survey of all sawing traces on the monument in view of a technical study

²⁵ With Ramadan Yassin, Jamal Salem, Hashem Abd El Hamid, Ahmed Youssef, Hamdi Adli, Ashraf Jamal, Samir Ahmed, Mohamed Abd El Sid, Girgis Ernest, Saadi Saadek, Mohamed Khalil, Walid Mohamed, Mohamed Abbadi, Salah Fahim (MoA-CFEETK).

on tools and methods used in its construction. Similarly, orthophotos from all sides of the chapel were made possible thanks to the high definition photographic survey of Jessie Maucor and the photogrammetric processing of Paul Mégard.

The chapel was officially opened for visitors by H.E. Pr. Dr. Khaled el-Enany, Minister of Antiquities, during his visit at Karnak on the 24th of September 2016.

Conservation of the Thutmosis III's chapel (C. de Oliveira)²⁶



The calcite chapel at the end of the work. © CNRS-CFEETK/Chr. Thiers.

The conservation-restoration work has followed the complete reconstruction of the chapel in order to restore the readability and appearance of the assembled elements and to ensure their good surface cohesion.

Condition report

A significant number of blocks were missing and replaced by masonry. Unity and legibility were being undermined by the very patchy appearance of reassembled blocks, color differences between them and the presence of deposits and dust on all of these fragments.

²⁶ With Nagwa Abd El-Ghafur and Fatma Ahmed Mohamed (MoA-CFEETK).



Northern wall before intervention. © CNRS-CFEETK/C. de Oliveira.

The blocks have been mostly reused in ancient masonry and then were exposed under different conditions. Thus, they had very heterogeneous surface appearance: some blocks were much dirtier than others.

Mainly in the ceiling, but also on the higher elevations parts, orange drops could sometimes be observed.

Moreover, the work was mainly affected by erosion. This was reflected in several ways: some blocks have undergone an advanced inter-granular erosion, carved ornaments have then faded and the crystalline structure of the rock has clearly appeared. On flat blocks, the sharp shape of corollas was characteristic of this damaged sedimentary rock: the grain of the stone fall easily as salts have crystallized below.



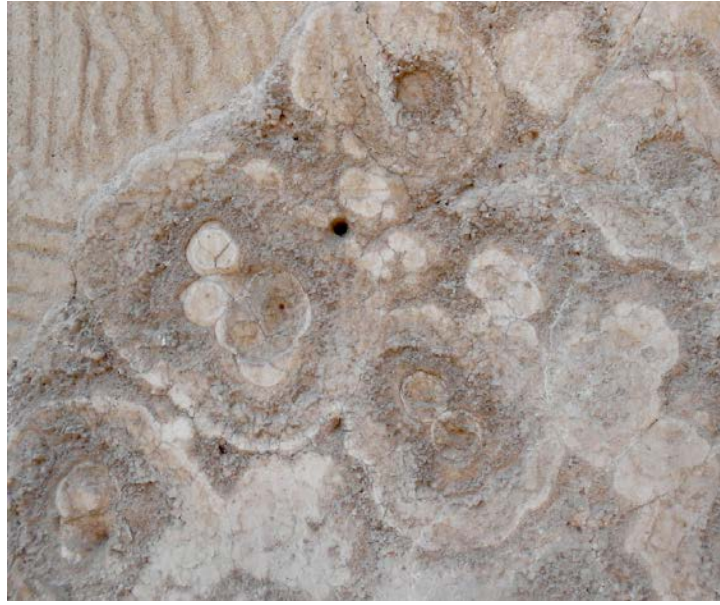

Upper left: Undamaged surface from one of the blocks. Upper right: Surface presenting light erosion. Bottom: Very advanced desagregation process. © CNRS-CFEETK/C. de Oliveira.

On other blocks, the surface was preserved, but had a serious surface fragility as powdering stone erosion occurred. Sometimes a very superficial and localized scaling could be observed.

Finally, the last type of alteration corresponded to marks and deposits left by the reassembling operations: the ceiling pins required the drilling of several holes of a few centimeters in diameter. These were visible on the upper part of the east side door, and less obviously in different parts of the ceiling stone. Temporary mortars applied for infiltration of liquid epoxy glue appeared very white (or pink for home-made hydraulic mortars) and so, impeded the aesthetic appreciation of the work.

The liquid epoxy adhesive had sometimes left traces that appeared more or less yellow on the surface of the stone.

Diagnosis

The blocks have mostly been reused in an ancient masonry, and then exposed under different conditions. It is probably the differences of the storage conditions that justify the strong differences from one block to another, as well as for the dirt or the surface erosion.

Everything suggests that the blocks have suffered from significant water leaks: there was a strong presence of soluble salts responsible for the loss of cohesion of the crystals on the most eroded blocks. Also, the layer of dirt under the surface of the stone was probably facilitated by the action of water.

Finally, the orange spots observed in different parts of the monument seem to correspond to the stone constituting colored elements themselves, which would have been moved to the surface of the stone. Once again, this phenomenon was probably caused by the action of water.

Before treatment, unity and readability of the monument were undermined by the reassembled blocks very patchy appearance, by chromatic differences between some blocks and the presence of heterogeneous deposits, dust and temporary fillings throughout all these fragments.

Treatment performed

A first dust removal has been performed using brushes and enema bulbs. It was followed by a water cleaning along with a soft brushing.

On the darkest and dirtiest blocks, we put a *hiba*/cellulose poultice (2:1 v/v) that we left applied for 24 hours, and that we then scraped off and rinsed with water and soft brush. Light *hiba* residues gave an abrasive effect to aqueous cleaning at their removal and thus allowed an optimization of the cleaning.

The orange concretions were dampened then scraped with a scalpel and a fiberglass pen. After testing several solutions, we have applied a 3% carboxy-methylcellulose aqueous gel, containing 3% EDTA and 5% calcium bicarbonate that we left for 30 minutes on the most resistant concretions before cleaning.



Orange strips on the ceiling before cleaning. © CNRS-CFEETK/C. de Oliveira.

Temporary fillings in PLM (lime and micronized silica mix ready to use) and lime mortar have been removed by scalpel and chisel after humidification.

The adhesive residues were softened by a solvent DMSO poultice, then scraped with a scalpel and rinsed with cotton swabs soaked in acetone.

On the stones with a granular erosion, we applied lime suspensions of nanoparticles in ethanol (Nanorestore). This was enough to give good cohesion and stabilize this very superficial damage.

On the more weathered stones whose original surface is now lost, where the matrix between the calcite grains disappeared, and where the grains were partially held in place by salts, we used some ammonium oxalate. For optimum processing, the latter was diluted to saturation (about 4.5% w/w) in water and applied with soaked cellulose powder compresses. These were then left to dry for 24 hours, protected by a plastic cover to reduce evaporation of the product. Dry poultices were then removed, leaving a much more cohesive and resistant surface.

For stone fragments with mechanical instability we have used liquid epoxy resin injections. The fragments have been prepared by the sealing of all the cracks with PLM grout, then, glue was injected with a syringe.

On every small gaps such as craters, pines holes or cracks, as well as all of the masonry cement of the chapel, we applied the finishing mortar formulated by Antoine Garric. This one was made from sand/stone/cement powder (4: 1: 1) dyed with natural mineral pigments after determining the ideal color for all areas to be filled and for covering walls.



Eastern side before intervention. © CNRS-CFEETK/C. de Oliveira.



Eastern side after intervention. © CNRS-CFEETK/C. de Oliveira.

When an illusionist rendering of fillings was wishable, we performed a colored reintegration. This has concerned the visible pins holes, as well as the indoor junction between the ceiling slab and the vestibule.

The touch-up on finishing mortars has been done with a natural mineral pigments tinted whitewash. The whitewash was then applied with a sponge or projected with a toothbrush.

2.2. The columns of the “Northern storeroom” no. 2

Two thresholds and a modern sandstone paving have been laid on the southern access to the storerooms (about 100 sq m.), thus finalizing the development work of the monument. On the parts where it was not possible to put a new pavement, a stone coloured mortar was realized at the same level as the pavement. By filling these gaps, it facilitates and secures the flow of visitors.



One column base totally destroyed (arenization process) in “Northern storeroom” no. 2. © CNRS-CFEETK/Chr. Thiers.

Two columns in the “Northern storeroom” no. 2 had to be restored and consolidated. Their bases and foundations being in extremely bad condition, they were threatening to collapse. The column shafts consisting of 12 half-drums, were however in good condition. To avoid a difficult dismantling and in order of efficiency, we decided to remove these columns but without disassembly. Thus, lifting them using the crane, but leaving them fully assembled, we moved them to store near the working area. They had of course been previously tightly fastened with vertical wooden reinforcements attaching them firmly sealed together.



The two columns standing upon their new bases. © CNRS-CFEETK/Chr. Thiers.

We then removed the weathered bases and cleared the perimeter of their foundations. These have been purged, consolidated by the addition of new stones and covered with a setting layer of sandstone paving. After an accurate survey of dimensions and section of bases, new ones were made in new stone. Finally, the columns were put back on the new bases, healthy and stabilized.

Note that a decorated stone fragment was unearthed when clearing the bases and was replaced at its original location on the north wall.

2.3. The walls of the “Cachette Courtyard”

The project of east and west walls reconstruction was initiated this year by:

- A complete inventory of loose blocks belonging to these walls made by G. Dembitz.
- Creation of a computerized classification system of blocks data. This system can be interrogated according to the block numbers, their current locations in the different lapidary deposits, their photograph numbers, their locations on reassembly walls or their layer numbers on the reassembly walls.
- Identifying and numbering 205 blocks and fragments. They will be moved from different lapidary deposits and transported to the reassembly area. This work was started in July and all the Open Air Museum blocks are already on the reassembly area.
- Removing blocks stored on walls and working area.
- Achievement of orthophotos of each wall faces, each fifty meters long.

Restoration-conservation (C. Bourse)²⁷

To prepare the intervention of reassembling the blocks in the Cachette Courtyard, several operations have been conducted:

- 12 disaggregated sandstone blocks stored upon benches in the Open-Air Museum have been silicated. They have been consolidated with ethyl silicate, Wachter OH100, mixed with white spirit (1.1) or ethanol (1.1).
- 8 fractured blocks have been glued with Araldite 2015, right after a protective layer of Paraloid B72 mixed at 15% with acetone had been applied. They have then been doweled with fiberglass rods glued with liquid Araldite 2011.

2.4. The gate of the southern Bubastite portal

The aim of the survey and dismantling of the eastern doorjamb was to allow access to the crane into the Cachette courtyard, but also to study the many reused blocks.

A. Garric realized orthophotos and plans of all elevation faces and all layers. The disassembled blocks were numbered, cleaned, consolidated, photographed and stored in a near lapidary deposit. This portico will be reconstructed to its exact original location once the walls of Cachette courtyard will be reassembled.

²⁷ With Nagwa Abd El-Ghafur, Fatma Ahmed Mohamed, Abdu Mahmud Quoraïem, Ashraf Mostafa Ali and Mahmud Said Ahmed (MoA-CFEETK).

3. CONSERVATION-RESTORATION PROGRAMMES (Camille Bourse)²⁸

Conservators were called for emergency operations on three temporary interventions:

- Conservation of inscribed bases from five sphinxes in the First Courtyard.
- Preservation and stabilization of the archaeological artifacts from the excavation at Ptah Temple (blocks, archaeological artifacts, coins and potteries),

Four conservation-restoration scheduled interventions:

- Restoration and enhancement of Tuthmosis III's chapel in the Open Air Museum (see above **2.1.**),
- Conservation of the Gate A' at the temple of Ptah,
- Conservation and restoration of the "Northern storerooms" nos. 1 and 2 in the central area,
- And finally, beginning of the interventions into the Cachette courtyard, including the conservation of some blocks (see above **2.3.**).

Two MoA conservators, Ashraf Mostafa Ali and Mahmoud Said Ahmed, underwent a 6 week training course dedicated to the conservation and restoration of metal. In doing so, they learned basics to clean, consolidate, stick and stabilize metallic objects.

3.1. The Sphinx of Pinudjem

Five sphinxes from the southern rows of the First Courtyard were showing important alterations and traces of decay.

Condition report

Structural alterations visible on the five sphinxes:

- gaps,
- breaks,
- cracks,
- important decay,
- subflorescence.

²⁸ The work was supervised by Camille Bourse and Abdel Nasser Ahmed, Chief of conservation. Many thanks to *rais* Mahmud Faruk for his technical assistance.

Team of ten Egyptian technicians and workers: Abdu Mahmud Quoraiem, Ashraf Mostafa Ali, Nagwa Abd El-Ghafur, Fatma Ahmed Mohamed, Abdelnasser Mahmud, Mahmud Said Ahmed, Ghaad Nubi Hussein, Mohammed Zaki Masoud, Said Abdel Hamid, Ahmed Hassan Fuli, and one trainee, Mohamed Mahmoud Abdin, and one international volunteer, Cécile de Oliveira. Manon Lefèvre (painting conservator) took part in the conservation of the Alexander's Chapel courtyard during 3 months (October-November 2015).



Some cracks and breaks are visible on the base.

We can also see an important arenization of the sandstone, with some hollows beneath the surface.

The left paw of the sphinx has been filled by cement during a previous restoration. Because of the salts, the cement filling is breaking off the sandstone.

© CNRS-CFEETK/C. Bourse.

Surface alteration:

- efflorescences,
- thick dust clogging.

We could also observe that a previous restoration put the sphinxes higher, with bases made of cement and baked bricks. Significant capillary rise was visible on the colored coating.



Traces of thick dust clogging

Salt efflorescence on the cement and brick base

© CNRS-CFEETK/C. Bourse.

Diagnosis

The structural alterations on sphinxes could be explained by two elements:

Due to the ancient level of the groundwater table, the cement and bricks bases were filled with salts which seeped inside the stone and cristallized inside it. Such a process provoked some breaks, cracks and the subflorescence.

On the other hand, the sphinxes closest to the First Pylon were partially buried under mud bricks “scaffolding” dating from the antiquity. This half-burying provoked a constant efflorescence which has destroyed by the time the stone structure.

The main superficial alteration, the dust clogging, was resulting from the fact that sphinxes are staying in a corner next to the “scaffolding” of mud bricks which pours its dust on them.

Aims of the intervention

The purpose of this work was to provide to epigraphists the opportunity of reading and copying the inscriptions on the bases of sphinxes, with no risks of further alteration. It was above all an emergency intervention with a minimal operation. However, as this area is opened to tourists, it was also important to give back a better legibility to the inscriptions, after the intervention.

The main goal was to stop the arenization of the sandstone. So, it was decided to take off the previous restoration to give access to the areas needing a treatment, so then, we could silicate and paste the fragments, before filling it again.

Treatment

An area has been cleared around the five sphinxes to give access to cement bases. Sandstone bases have been cleaned with brushes then the cement fillings were taken off.

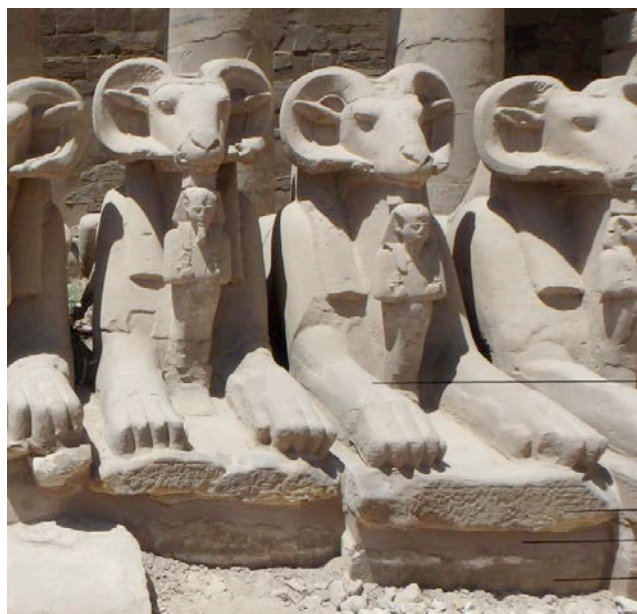

Cement fillings

Inscribed plinth, which has been cleaned and consolidated.

Filling, after a treatment made with lime.

Base made of cement and baked bricks.

© CNRS-CFEETK/C. Bourse.

To prepare the solidification of sandstone, some drillings have been made to introduce a drip system. Small fragments have been put into a plastic box to apply a consolidation by capillary rise. These fragments have been soaked with ethyl silicate, Wacker OH100, mixed with ethanol at 50% during several hours. After this operation, the sphinxes have been put under protective canvas for three weeks.

Fragments have been stuck with Araldite 2011 charged with micronized silica. Finally, the fillings and a finishing coating colored with lime and sand (1.3) have been applied, aiming not to attract attention of tourists. Nevertheless, it should be noticed that these sphinxes are in a really bad state and would need a full restoration campaign.

3.2. Temple of Ptah Conservation of the Gate A' (C. de Oliveira)



The Gate A' before intervention. © CNRS-CFEETK/C. de Oliveira.

The intervention was focused on a set of blocks belonging to the Gate A' located on the southern area of the Ptah temple precinct. Only two courses of the gate and two bases (probably for statues) built against its western side were preserved.

The southern doorjamb was partly built with sandstone talatats reused in the masonry, some of them bearing reliefs or inscriptions. An original mortar was present inside the joints and sometimes as a thick surface layer.



The gate after intervention. © CNRS-CFEETK/C. de Oliveira.

Condition report

Since its excavation, this gate has not been valued, and the stones were in an advanced state of degradation. The sandstone was highly disaggregated. This disintegration was more marked on the blocks from the lower courses and/or partially buried.

Several cracks were observed on the blocks mainly on the northern doorjamb and statue bases. Some blocks were completely ruined by a combination of arenization and fragmentation. Some of the blocks have been moved from their original location.

Between the stones, the joints were mostly filled with sand and dust. It included many *alfas* plants whose roots had grown inside the joints and in the stone themselves when they were disintegrating. These plants were, at that point, fully withered.

Antic mortars had very low cohesion and adhesion with the stone.

Diagnosis

The stones disaggregation, as it is commonly observed in the temple, was mainly due to the presence of soluble salts and capillary rises of water. This has probably been greatly enhanced by the unearthing of the gate.

The arenization is usually accompanied by breaks. They are often related to a difference in the blocks cohesion between arenized parts and those that are not. The plants growing then just add mechanical stress in fragile stones. The disintegration of old mortars and therefore the joints also follow the same logic.

Aims of the intervention

The aim of the intervention was to stabilize the building. This, not only in order to slow the degradation, and to highlight the value of the building, but also to anticipate a possible trampling by visitors.

In addition, and to make the archaeological material that the talatats represent accessible, we planned to extract them.



Talatat fragment extracted from the masonry. © CNRS-CFEETK/C. de Oliveira.

Treatment

The talatats or talatats fragments decorated with reliefs have been extracted. They were all in a very poor cohesion, and they were immediately impregnated with ethyl silicate.

The arenized sandstones kept in place have been purged. The purge affected all of the northern doorjamb on approximately ten centimeters in its lower part. It also represented an important work on the south and west sides of the southern doorjamb. It was more anecdotic elsewhere.



Arenised sandstone during its purge. © CNRS-CFEETK/C. de Oliveira.

In the joints, the dust has been removed. The small sandstone pebbles formerly used for reinforcement of masonry were set aside for being reused in filling mortars.

The already whitered plants still had a high mechanical strength and were highly tangled. They were removed when it did not pose a risk for stones or old mortar remains still present.

Before the mortar application in the gaps left by the purged sandstone, the inner edges of the hollow were isolated on five centimeters from the sandstone surface with a 15% solution of Paraloid® B72 in acetone. This has prevented the attraction of the stone salts by mortar water. Indeed, this phenomenon usually leaves brown halos around the edges of the joints.

A lime masonry was used to fill the voids induced by the purging and removal of dust. This masonry was carried out with a mixture of one part of lime for three parts of sand and half a part of baked brick to give the mixture some hydraulic properties. A finishing layer of mortar was applied over this filler. This mortar was composed of a part of lime and two parts of sand. The whole had been sieved to a millimeter then stained with a mixture of natural mineral pigments.

The repairs of broken fragments were made with epoxy. Stones slices were previously isolated under the spots of adhesive with a 15% (w / w) solution of Paraloid® B72 in acetone. For fragments that could suffer from high mechanical stresses, a reinforcement was added to the bonding in the form of a stud of fiberglass. It has been attached to different fragments glued by epoxy injection into the drilling.

The antic mortars significantly present on the southern doorjamb surface have first been dusted with a soft brush. Then, they have been consolidated by the application of a 4% ammonium oxalate solution (Amox®) in water. The fragments were repositioned and reattached with Primal® AC33 (acrylic emulsion). Edges of very fragile or very raised up areas have been consolidated by the application of a thin lime mortar of the same composition as the finishing layer mortar.

Archaeological finds (C. Bourse)

The 2015-2016's excavation campaign has led to the discovery of little metallic objects, one polychrome pottery and limestone fragments carved with decorations.

Metallic objects have been mechanically cleaned using scalpels and micro sand-blasting. Pastings were made with an epoxy glue, the Araldite 2015.

The polychrome pottery has been consolidated with CMC at 2 % mixed with water.

Two limestone fragments, a little stela depicting a goose and a sundial were submitted to distinguished treatment.

The stela, which was in a good state of preservation, only needed a mechanical cleaning, then an aqueous cleaning.

However, the sundial, which was in a very altered state, was powdery and presented fragmentation on the surface area.

To prevent the loss of any fragments during the discovery, some Japanese paper has been glued on the surface area with Carboxyle methyl cellulose (CMC) at 3% mixed with water. Then, once unearthed, Japanese paper has been removed and the CMC diluted. Finally, limestone fragments were stuck back and injections were made using an acrylic glue, some Acril 33 at 20 % mixed with water.

Coins

Those are the 77 coins discovered during the excavations of Ptah in recent years. We decided to realize only one conservation report for all the coins at once because they all revealed the same alterations, although at different stages.

Condition report

The coins are made of a copper alloy, and most of them were extremely altered. To make the understanding of this report easier, coins will be separated in two groups: some coins, about 20 of them, which are “normally” altered, and the other coins in which the corrosion reached the core of the coin, making impossible any further study.



On the left, the corrosion reached the core of the coin, making its scientific exploitation very difficult. However, on the right, corrosion is superficial. After cleaning, inscriptions will be readable again. © CNRS-CFEETK/C. Bourse, E. Saubestre.

Structural alteration

All the coins show the same external alteration:

- the first level is compound of aggregates and soil residues,
- under it lays a quite hard blue layer made of copper carbonate,
- then a thick reddish-brown layer made of copper oxide,
- beneath that, a black then golden patina,
- and finally, metal just below.

We also observed that the whole coins showed some turquoise-blueish spots of active corrosion.



Copper carbonate

Black patina

Agregates and soil residues

Active corrosion

© CNRS-CFEETK/C. Bourse.

In case of extremely altered coins, the active corrosion attacked the central core of the metal, provoking, in the best-case, a detachment of both surfaces, and sometimes the complete disappearance of the metal. So, the coin was only made of corrosion.

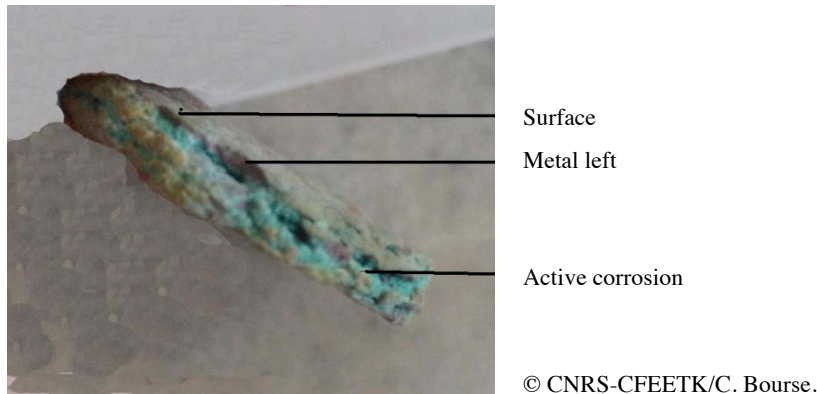

Diagnosis

The state of those coins can be explained by their burying conditions: in Karnak, as the groundwater is pretty high, coins were constantly subject to a metal alteration process. Moreover, after their discovery, coins were put into plastic bags which were not always pierced to provide ventilation. That might have rushed the alteration.

Treatment

At first, coins have been cleaned mechanically using scalpels, then micro-drills. Secondly, to make the corrosion's dissolution easier, they were put into a solution:

- first, into hexametaphosphate at 5% mixed with demineralized water,
- then, into EDTA tetrasodium at 5% mixed with distilled water.

The coins with no visible damages have been cleaned into an electrolytic bath with a solution of triammoniumcitrate (TAC) at 5% mixed with demineralized water. These coins did never receive that treatment more than 30 minutes. After that, they were put off the bath and cleaned with toothbrush and water, then with scalpel.

Every coins treated by a chemical cleaning have been rinsed with demineralized water during 10 minutes, then have been dried and soaked into ethanol.

The filling of cracks and the pastings have been realized with Paraloid B72 at 15% mixed with acetone.

Finally, coins have been put back into their plastic bags, which were systematically pierced to prevent any condensation and so, to prevent any further corrosion. After being photographed, these coins will be sealed into a plastic box with adhesive tape. Some silica gel will be added into the box to prevent any variation of relative humidity.

3.3. The “Northern storerooms” 1 and 2 (C. Bourse)

Located north of the *Akh-menu*, “the Northern storerooms” are made of seven consecutive rooms. Storerooms nos.1 and 2 differs from the others because they do not contain any false ceilings. Storeroom no. 1 give access to a corridor which border the back of the whole storerooms, and was probably used, during Antiquity, to supply the site. Storeroom no. 2 differs by the presence of two columns and buttresses formerly bearing the ceiling.

Following the interventions made in 2014-2015, we restored storerooms nos. 1 and 2, so that the renovation of this architectural complex is now over and can be opened to the public.

Condition report

The general state of the northern storeroom no. 1 (MN1) was not as good as in northern storeroom no. 2 (NM2). Both storerooms got many common elements missing: foundations blocks, architectural supports... They were replaced, in modern times, with cement masonry.

Moreover, it should be noticed that both storerooms were subject to renovations during Antiquity, due to the implementation of new architectural elements, such as a door, two supporting columns and architectural reinforcements in the southern area. Some of these achievements have been realized with limestone and calcite blocks, which differs of the whole complex made of sandstone.

Concerning the recorded alterations, they are similar in both storerooms, so we will list them together.

Alterations

Structural alterations in both storerooms:

- advanced arenization of the foundation,
- powdery upper blocks,
- significant salt rising,
- many gaps,
- fragments dissociation,
- breaks,
- cracks.



Storeroom no. 1 (on the left) and no. 2 (on the right) before intervention. © CNRS-CFEETK/C. Bourse.

Surface alterations:

- thick dust clogging,
- powderiness of the preparatory mortar
- efflorescences.



Northern storeroom no. 1 before treatment: cement colored coatings are filled with salts visible by white spots and lifting fragments of stone.

© CNRS-CFEETK/C. Bourse.

Diagnosis

As we told in the introduction, we have noticed a difference of state between the two storerooms. It can be explained by the fact that MN2 was used as a storage for scattered blocks, making its access difficult, whereas MN1 was sometimes used as “toilets”.

Moreover, both storerooms have been subject to important interventions of adding cement masonry to fill the missing elements. Those elements got spoiled over time, so moisture marks and efflorescences appeared.

Aims of the intervention

Like the rest of the north storerooms, the main goal was to slow down the alteration process of the foundations by removing the cement masonry and unearthing the sandstone blocks to bring gradually the salts out.

Then, we had to choose a conservation-restoration treatment which would be suitable with the environment and the previous treatment made in the north storerooms. That means, to take account of the closeness of the nilometer with its significant capillary rising, the showing off of the complex and the consolidation of polychrome elements constantly exposed to the sun.

The third goal was to put back in their initial place as much blocks as possible.

Finally, the aim of this intervention is to enhance those storerooms, so they will be opened to the public.

Treatment

Storerooms nos. 1 and 2 contained a very few desintegrated sandstone foundations blocks but many of the blocks in the lower part of walls have been replaced by a cement masonry. In front of such an important reconstruction, we decided to remove the cement masonry only when it was in touch with the antic sandstone blocks.



Only the colored coating has been removed, showing a cement and bricks masonry. © CNRS-CFEETK/C. Bourse.

However, the finishing colored coating and the sided coating have been removed everywhere to let the crystallized salts on the surface.



To prevent the inner salts to cristallize inside the stone, a caisson of lime mortar and stones has been realized. Salts will cristallize on the surface.

© CNRS-CFEETK/C. Bourse.

The scattered blocks which overfilled the storeroom no. 2 have been removed and put upon storage benches in the north of the temple. Their provenance has been inscribed on the edge of each block.

The three scattered blocks from the storeroom no. 1 needed the pasting of fragments with Araldite 2011 charged with micronized silica. Some isolation tiles of Paraloid B72 at 15% mixed with acetone had already been placed to prevent any direct contact between stone and Araldite. Once that operation done, blocks has been dowelled with fiberglass rod glued with Araldite 2011. They were then put back to their own place. When intermediary bases were missing, stones have been put on wood spacer to indicate their original place.



Block being removed. © CNRS-CFEETK/C. Bourse.



To complete this block, a masonry made of lime and cement (50/50) has been set up. Once complete, the block has been put back to its original location.

© CNRS-CFEETK/C. Bourse.

Inscribed blocks which were disintegrating inside the storeroom no. 1 have been silicated with ethyl silicate, Wacker OH100, mixed at 50% with ethanol. They were then covered for three weeks.

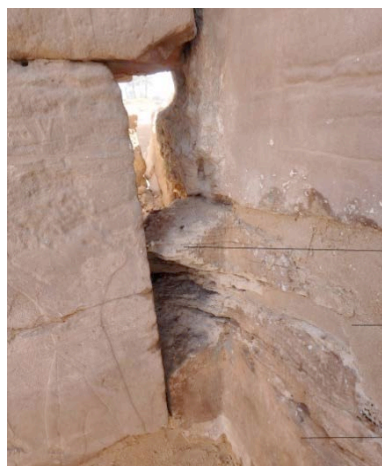

Silicated stone

Area filled with lime and sand mortar (1.3)

Silicated area

© CNRS-CFEETK/C. Bourse.

Fragments getting off the surface have been glued with Araldite 2015. A protective layer made of Paraloid B72 at 15% mixed with acetone had previously been applied.

A fragment of the scene in the storeroom no. 2 has been discovered. By the way, it was replaced with a lime and sand mortar (1.3).



Filling in lime and sand mortar (1.3)

Fragment discovered inside the columns foundation and put back in its original location

© CNRS-CFEETK/C. Bourse.

A door allowing circulation inside the storerooms had been closed since Antiquity with a sandstone then a limestone blocks. The latter was really altered and was disintegrating in slices. To prevent its complete loss, a coating made of lime and sand (1.3) has been applied and a hole has been kept to indicate that there was a gate. The finishing colored coating do not match the color of sandstone. It shows a quite whiter shade indicating that the stone beneath is in limestone.

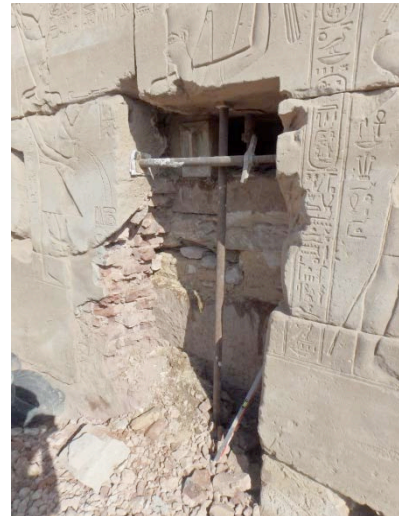

The left picture shows the door before treatment. We can see that the limestone is pretty altered: it is disintegrating into chips. To prevent any risk of falling, a masonry made of lime and sand (1.3) has been realized. To indicate the presence of this limestone block, the finishing coating is lighter colored. © CNRS-CFEETK/C. Bourse.



An opening has been left to highlight the filling stones behind the door, indicating the different stages of construction.

The limestone filling block has been strengthened by adding a masonry. The finishing coating is in light color to indicate that it covers a limestone block.

© CNRS-CFEETK/C. Bourse.

White coatings have been consolidated with ammonium oxalate at 5% mixed in water and traces of red polychromy in the storeroom no. 1 have been consolidated with Lucel at 3% mixed with ethanol water.

Finally, the bases of the two columns in the storeroom no. 2 suffered from a significant arenization. It was thus decided to install two new blocks carved in healthy stone. This operation was led by Antoine Garric's team (see above **2.2.**).

3.4. The vestibule of the Alexander the Great's chapel (M. Lefevre)²⁹

The epigraphic programme of the *Akh-menu* is closely linked with a conservation work planned on this area. After two seasons devoted to the conservation of the chapel of Alexander the Great, this mission dealt with its vestibule (AKM.SX.4).

Condition report

Like a lot of areas of the temple of Karnak, the vestibule has already been restored in the first half of the 20th century. Indeed, we could see the presence of an old cement mortar used during a previous restoration still present between the blocks.



Sample of the old mortar of restoration using cement. © CNRS-CFEETK/M. Lefevre.

²⁹ This work was carried out from 19 September to 19 November 2015 under the supervision of Dr. Mohamed Abdel Aziz and Dr. Christophe Thiers, and Abd Al-Nasser Ahmed (MoA chief conservator). Funding from Univ. Tübingen, Santander Bank. Team members: Mohammed Gad Ahmed, Marwa Hassan Mosalem, Anwer Fouad et Amira Yousef Abul Hagag; inspector Yasser Moushtafa and Ahmed Kamal under the supervision of Tayeb Gharib, chief inspector. I am pleased to thank the French restorer Camille Bourse, her team for the masonry work, Antoine Garric and his team for their intervention, and Rais Mahmud Farouk for his help.

An old cement restoration mortar was joining all the sandstone blocks and thus, was degrading the original stone. The cement, preventing the stone from breathing, made that stone becoming powder. The stone was badly weakened, and in some places, was loosing cohesion and presented cracks. Moreover, because of the humidity and the groundwater, the walls presented a lot of salts..

On the surface, there were a lot of droppings (birds, bats...), splashes and a lot of dust.

The antique coating was very degraded and powder. It was only still visible on the walls and more on the main facade (East).

The pictorial layer before restoration seemed very poor. We could see some pigments but they were very altered. The color was hided by the dust and presented cohesive and adhesive losses.

Because of all these alterations it was important to conserve and restore this place. Indeed, we had to bring back the legibility and visibility of its decors, to consolidate its structure but also remove old restoration in order to adapt the treatment.



SOUTH WALL,

- | | | | |
|---|-----------------------------|---|------------------------------------|
|  | Animal dejection, splashing |  | Old mortar of restoration (cement) |
|  | Hammering |  | Salt |
|  | Gaps, missing parts |  | Cracks |

Schema of the various alterations that compose of the antechamber of the chapel of Alexander the Great. © CNRS-CFEETK/M. Lefevre.

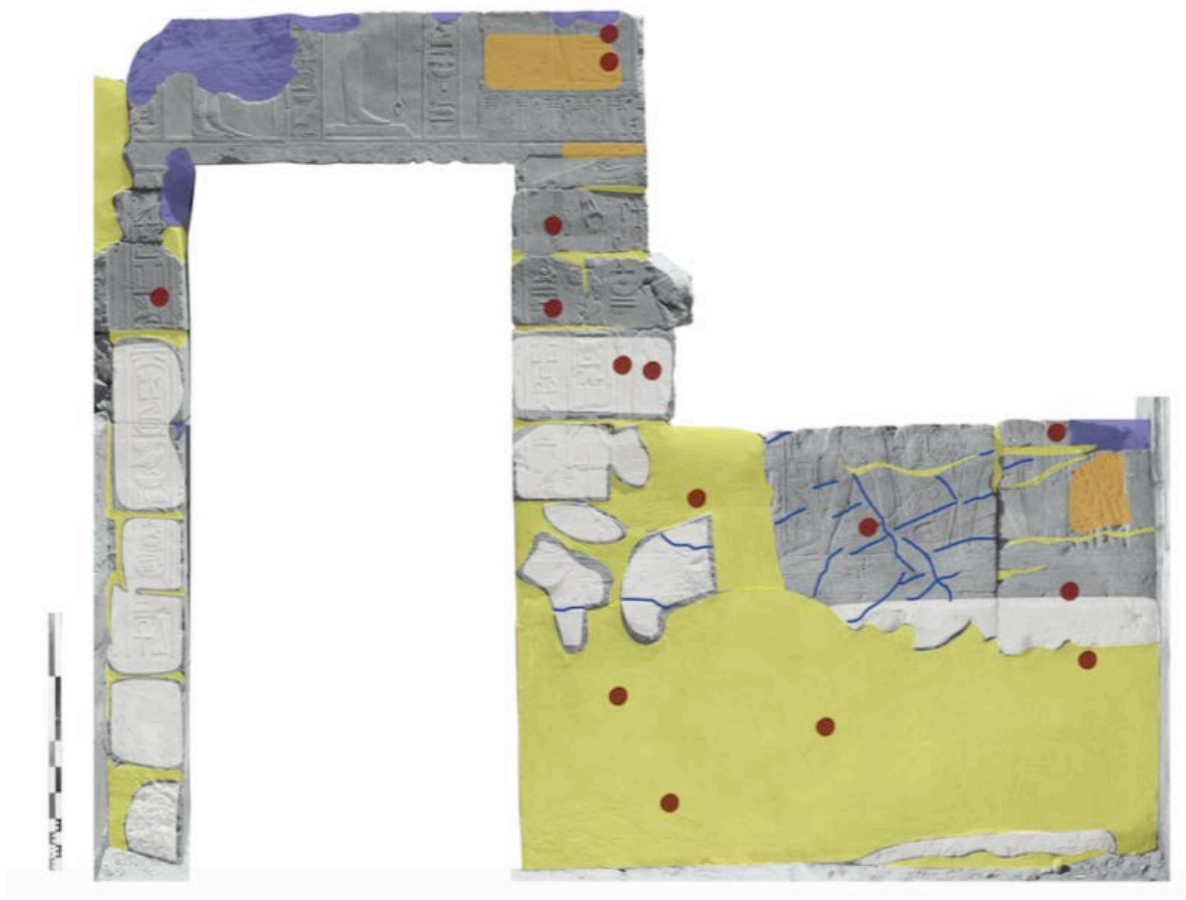

NORTH WALL, ALTERATION :

	Animal dejection, splashing		Old mortar of restoration (cement)
	Hammering		Salt
	Gaps, missing parts		Cracks

Treatment proposal

- 1- Removal of the old mortar of previous restoration;
- 2- Re-adhesion and consolidation of the blocks;
- 3- Mechanical and chemical cleaning of the support and of the pictorial layer;
- 4- New restoration mortar: two top layers;
- 5- Removal of salt on the lower parts of the walls;
- 6- Consolidation of pictorial layer;
- 7- Addition of a colored mortar;
- 8- Removal of the dust on all the blocks and the pictorial layer.

Removing of the old restoration mortar

This intervention was necessary for the durability of the stones. Indeed, the composition of this mortar was asphyxiating the stone and was trapping the salt present in the rock, causing a degradation of the sandstone.

The removal of the old restoration mortar, made of cement, was done with the chisel and hammer for small areas and with the drill for the big parts.

During the removal of this mortar, we observed that the cement was made with red clay, small stones and red bricks. During the removal, we had to proceed in different steps. First, the removal of the first layer (black cement) and then the removal of the clay binder and non-original stones.

Unfortunately, for some lower parts of the facades (mainly on the west wall), as the stone was very altered, it was turning into sand and was losing cohesion. Therefore, it was necessary to remove all the sandy part in order to “purge” the stone.

Consolidation of support and re-adhesion of blocks

During the removal of the old restoration mortar, we noticed that it had caused many alterations in the cohesion of the stone. Thus, many parts of the walls had to be consolidated and replaced to their original location.

For this, it was necessary to divide the work into two parts. In first time, it was necessary to consolidate the fragile parts. For this, Paraloid B72 concentrated to 3% or 5% in acetone (depending on the alteration of the stones) was applied with a brush. This treatment was applied to the accessible and uncovered parts. For the hollow stones, we injected liquid Araldite (5 portions of Araldite AY103 and 1 portion of Hardener HY956) with a syringe.

Once the consolidation was finished, we could replace the blocks. First, a layer of Paraloid B72 has been applied on the surfaces where the adhesive would be applied. It will be a barrier between the stone and the adhesive so that the adhesive doesn't penetrate the pores of the stone and to ensure the reversibility of the intervention. The adhesive, made of Araldite 2015 in paste form has been applied with a glue gun in checkerboard pattern on the selected parts on the stone.

Cleaning and Desalination

For the cleaning, we decided to use 3% of ammonium bicarbonate in demineralized water, 3% of Ethylene Diamine Tetra-Acetic acid (EDTA) and 3% of carboxyl-methyl-cellulose (CMC). It was applied on a paper with a brush and left for 10 minutes. Because of the ambient temperature, we used the CMC in the mixture to have a longer action. The paper was then taken off and the surface was cleaned with demineralized water and brush to remove the residual solvents.

Cleaning revealed pigments still present on the East and North walls, such as blue, red, green and yellow.

For the lower parts, salts could be seen. At the beginning, we used hiba to remove the salt, but as the results were not conclusive, we chose another technique consisting in the combination of solvent and a cellulose compress to clean and to remove salt. Thus, 3% of CMC has been applied on paper onto which we put a compress composed of cellulose pulp, demineralized water and 4% of CMC. Once the compress was removed, it was easier to remove the salt with a scalpel and a brush.



North wall: Cleaning with a toothbrush and demineralized water. © CNRS-CFEETK/M. Lefevre.



North wall: removing of salt with a compress (3% of CMC and pulp of cellulose).



South wall: Removing salt with *hiba* (Egyptian clay). © CNRS-CFEETK/M. Lefevre.

Installation of the new restoration mortar

In order to recreate the structure of the walls and the link between each block, a mortar has been applied, in 3 steps:

1. The first layer as a base composed of one portion of lime for three portions of sand. In order to reinforce this first layer, crushed stones were added on this base. On this first mortar was applied a whitewash consisting of one portion of sand for one portion of lime, giving a rough appearance to ensure a better grip for the next layers.
2. The second layer was composed of the same percentage of sand and lime but this time there were no crushed stones. For this layer the sifting is tighter than the first layer. Thus, the appearance and the thickness are finer.
3. Finally, the last layer was composed of one portion of lime mixed with pigments: 10g of brown and 25g of yellow. Once the color has been done, three portions of sand were added to the mixture.

Between each step it was very important to humidify the various supports.

For the interstices between each block, a mortar has also been applied. To do this, a first layer, made of one portion of lime with three portions of sand, was put with a small spatula. Once dry, a colored layer was added.

Consolidation of pictorial layer

After cleaning, many colors appeared. It therefore seemed essential to strengthen them. Considering the climate and exposure of the facades, Klucel G seemed the most interesting to consolidate the pigments. It was used at 3% in ethanol and demineralized water (50:50). The Klucel G has been directly applied on the colored layer with a brush.



East wall: Consolidation of the pigments Klucel G at 3%. © CNRS-CFEETK/M. Lefevre.

There was little residues of the preparation layer, mainly located on the East facade. To preserve them, 3% of ammonium oxalate in water was applied with a brush. Thus, despite the great degradation of this layer, the few vestiges of this antique plaster could be consolidated for a better durability.

Thanks to the consolidation, the colors have been revived, so that the public can see more colors today than before the restoration.

Conclusion

The objective of the restoration of the antechamber of the chapel of Alexander the Great was to give a new legibility to the wall for the study of Egyptologists and to give to the place a better durability. The main interventions were the removal of the old restoration, the cleaning of the wall and the consolidation of the support and the pictorial layer.

Thanks to this restoration, we were able to improve the legibility of the hieroglyphs and the visibility of the colors.



East wall: Colors after consolidation.

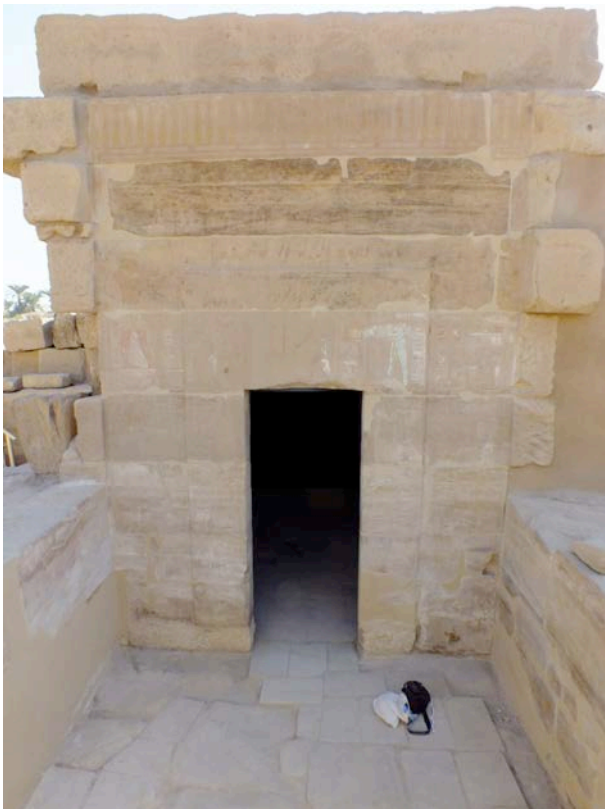

The walls of the antechamber of the chapel after restoration: East wall (left), South (top), West (center) and North (bottom). © CNRS-CFEETK/M. Lefevre.

4. ARCHIVES AND SCIENTIFIC DOCUMENTATION

4.1. Scientific archives (S. Biston-Moulin)

Photographic Archives Database

The work on the scientific archives of CFEETK continued in 2016. The annual production of the photographic center was integrated into the archive with a little over 30,000 documents added this year. Work on the *Karnak project* (see above) facilitated the reorganization of existing CFEETK archives and the addition of new documents by linking scientific information of the project to photographs from the archives of CFEETK. The inventory work of the inscriptions in the temple also allows to complete archives through the identification of objects and scenes for which photographic documentation preserved in the archives of CFEETK is insufficient. A photographic survey based on this inventory was set up with the photographic service of CFEETK in 2014 and continued in the past two years.

Scientific Archives service of the CFEETK was also involved in the establishment with a team of inspectors from the Center of the “Karnak Inventory Project” which aims to reference and document all objects and blocks stored in the temple.

In 2016, access to Scientific archives of the CFEETK was made available online (<http://www.cfeetk.cnrs.fr/archives/>). This interface combines all sources of information and projects of the unit (*Karnak project*, ArcheoGrid Karnak, bibliographical project). It received nearly 500,000 visitors and photographs were downloaded more than 1.000.000 times. The number of high-resolution photographs available rapidly increases in connection with the publication of the document in the *Karnak project*.

The screenshot displays the 'Archives du CFEETK' website interface. At the top, there is a search bar labeled 'Rechercher'. The main content area is titled 'Exploration topographique' and is divided into several sections:

- Parvis du temple**
 - Chapelle d'Achôris
 - Stèle du dromos ouest
 - Objets découverts
- Grande cour et premier pylône**
 - Sphinx au nom de Masaharta
 - Objets découverts
- Salle hypostyle et deuxième pylône**
 - Salle hypostyle
 - Montants de porte
 - Statue d'un roi agenouillé présentant une table d'offrandes de Séthi II
 - Statue porte-enseigne de Séthi II
 - Statue porte-enseigne de Séthi II
 - Stèle de la campagne nubienne
 - Objets découverts
- Zone des pylônes centraux**
 - IIIe pylône
 - « Porte » de Ramsés IX
 - Cour nord du IVe pylône
 - Cour sud du IVe pylône
 - Cour nord du VIe pylône
 - Cour sud du VIe pylône

The main content area features a detailed entry for 'Statue Louqsor J. 34 (Sésostris III)'. The entry includes the following information:

- LOCALISATION DE DÉCOUVERTE :** ZPC.CR3.n - Zone des pylônes centraux, cour nord du troisième pylône
- LOCALISATION ACTUELLE :** Musée de Louqsor
- Description:** Partie supérieure d'une statue de Sésostris III découverte devant la face ouest du môle nord du IVe pylône lors de l'opération 40. La tête a été découverte le 25 février 1970, entreposée au Caracol, elle est aujourd'hui conservée au Musée de Louqsor (J. 34). Le reste du buste a été mis au jour en 1980. Des fragments découverts en 1970 complètent la partie inférieure de l'inscription du pilier dorsal qui semble très proche des statues CG 42011 et 42012.

Below the text, there is a grid of photographs showing different views of the statue fragments. The grid is organized by date, photographer, format, and type. The visible photographs are labeled with their respective IDs: Cfeetk 27921, Cfeetk 27922, Cfeetk 27923, Cfeetk 80371, Cfeetk 80372, Cfeetk 80766, Cfeetk 80767, and Cfeetk 80768.

Topographic exploration of the archives of CFEETK.

Access to photographs is through topographic exploration of the temples of Karnak (temple areas, monuments, object, etc.), by date or author of photography. A search engine completes these tools to provide chronological access to photographs.

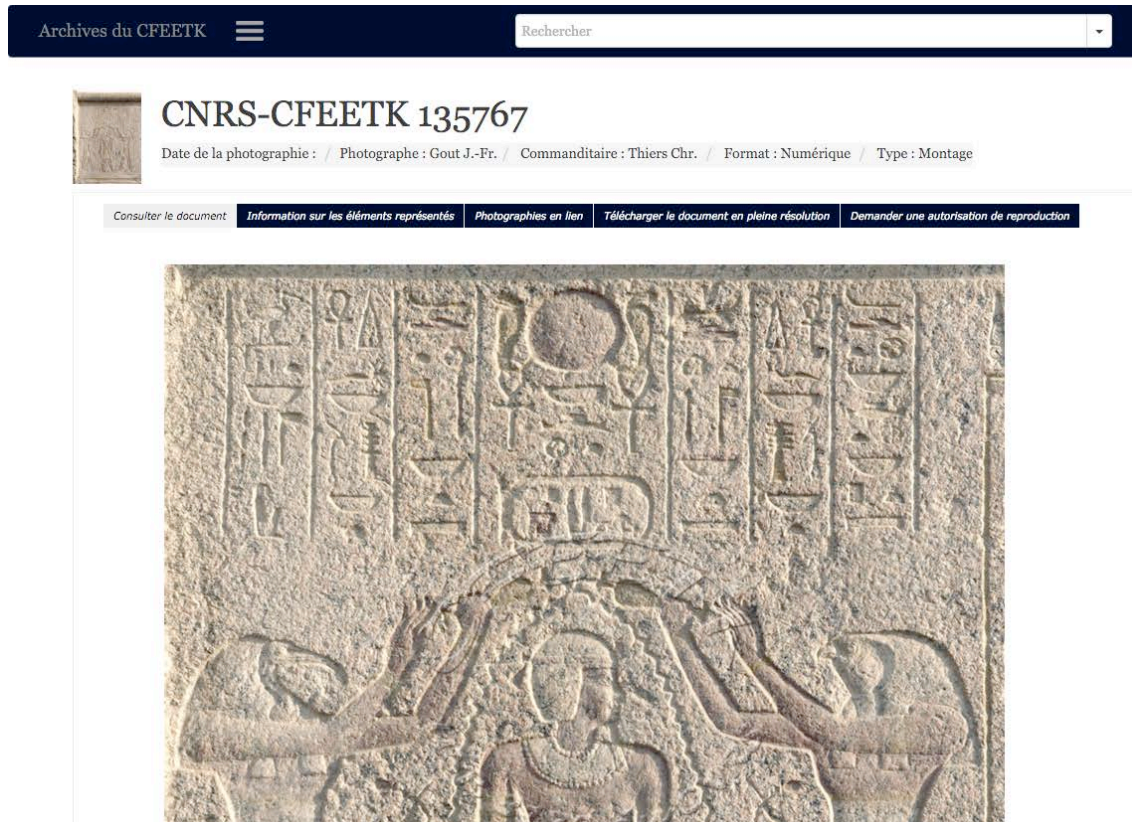

The screenshot shows the website interface for Archives du CFEETK. At the top, there is a dark navigation bar with the text "Archives du CFEETK" and a search box labeled "Rechercher". Below this, the main content area features a small thumbnail of the relief on the left and the title "CNRS-CFEETK 135767" in large, bold letters. Underneath the title, there is a line of metadata: "Date de la photographie : / Photographe : Gout J.-Fr. / Commanditaire : Thiers Chr. / Format : Numérique / Type : Montage". A horizontal menu bar contains several options: "Consulter le document", "Information sur les éléments représentés", "Photographies en lien", "Télécharger le document en pleine résolution", and "Demander une autorisation de reproduction". The central focus is a large, high-resolution photograph of an ancient Egyptian relief. The relief depicts a central figure, likely a deity or a royal figure, with arms raised, flanked by two other figures. Above the figures are several columns of hieroglyphs and symbols, including a sun disk and a lotus flower.

A high-resolution photograph in the interface of the Archives of CFEETK.

Opened with a little over 10,000 photographs in full resolution, there is today a little more than 20,000 photographs in full resolution freely downloadable online from the scientific Archives CFEETK.

The whole of accessible documents is deposited in Nakala, service set up by the very large facility Huma-Num (<https://www.nakala.fr/>) for the storage, documentation and enrichment of data in a secure warehouse that ensures both accessibility data and quotability in time.

Library of CFEETK

The library of CFEETK was enriched by about 100 new books this year. In addition to members of the Franco-Egyptian Centre, the library has hosted many inspectors and Master students of the University of Qena throughout the year.

Website

The website of CFEETK welcomed more than 320,000 visitors this year and more than two million visitors since its launch in March 2009.

The website of CFEETK, as all projects of the unit hosted by In2p3, experienced technical difficulties since March 2016. Access to some functions had to be temporarily limited, especially for the English and Arab versions of the website. We study the solutions to solve these problems as soon as possible.

4.2. Photographic department (É. Saubestre)³⁷

The photographic department's activity has mainly focused on the finalization of the photogrammetric survey in several areas of the temple in order to complete the *Karnak* Project and to make available online high resolution photographs.

Therefore, all disparate photography data held by Centre around the central area of Amun-Ra temple have been completed. Also, the survey of the "Northern storerooms" and the northern rooms of *Akh-menu* have been finished as well as the photographic survey of Opet temple

At the end of the anastylosis and the cleaning of Thutmosis III's chapel in the Open Air Museum, a complete orthophotographic survey has been done. The objects found during Ptah temple's excavation as well as Osiris Ounnefer Neb-djefau chapel have been photographed in the studio.

The re-digitization working programme of the Centre's analogue archive in high definition continues.

4.3. Topographical department (P. Mégard)

The surveyor's activity this season was following on from the actions of the last year, in support of the archaeologists and egyptologists teams.

The support to the archaeologist's activity was very important in order to produce some accurate documents. For the excavation of 12m side and 6m depth on the South of Ptah temple, some topographic surveys and ortho-corrected pictures had been done for each step of the excavation to keep in memory the found structures and ceramics. All this documentation has been digitized, classified and included in the Karnak's plan. These actions enabled to advance in the excavation and to make a complete archiving of all the archaeological structures and levels. The used methodology by P. Megard is the same one used by his predecessors, some improvements have been done, especially to update the softwares for the photogrammetry. The work site permitted also to make some 3D models as to represent the excavation of 12m in a video. Thus, the archaeologists could use it to present their work.

The other task of the topographic service was to continue the ortho-corrected pictures of some temple's walls for the department of the scientific archives. That permits to the department to get good pictures for the epigraphic working and to be able to archive this documentation, and to make it reachable for the public by the website.

P. Megard checked also the management of the Karnak's archaeological plans. At the end of the season, he had to check all the central part of the temple because there were some errors (wrong digitization, missing part, incorrect informations...). This work allows to submit publications with updated plans.

A collaboration with the Egyptian colleagues of the CFEETK was set up. A presentation and a training programme about the surveyor job had been done regularly for some inspectors of the center. Moreover, a

³⁷ With K. Dowi Abd al-Radi and A. Ruby (MoA-CFEETK).

collaboration with an Egyptian surveyor permitted to exchange on the each working method. And so, they could improve and extend their range of activities (3D modelling, photogrammetry).

Finally, two Polish geophysicists came two weeks in Karnak to make an electromagnetic survey on some areas of the temple to detect archeologic structures. P. Megard provided additional support to them, he made a very accurate grid pattern on the chosen areas.

4.4. The scattered blocks survey

The inventory work of the loose blocks lying upon benches has continued, using the same protocol as in the previous years: numbering on a piece of metal, schematic drawings, photography and incorporation into a database.

For the second season, a team of Karnak inspectors (scientific department),³⁸ using booklets made by S. Biston-Moulin, is currently working on a complete survey of the blocks, statues and stelae present inside Karnak temples. This documentation team successfully made the inventory of the blocks of the central area of Amun-Re temple. This work will continue next season.

³⁸ R. Mohamed, R. Sabri, A. Fawzy, A. Hassan, M. Ali, A. Mohaamed, A. Mohammed, M. Ahmed, B. Fady, M. Ramadan, S. Nur Eldin, M. Nur Eldin, S. Mohamed (MoA-CFEETK).

5. TRAINING PROGRAMMES

Training is provided for shooting and processing images by the photographic department. Trainings to epigraphic survey techniques and digitization software (digitally inked drawings) were provided to the inspectors wishing to acquire these techniques.

Similarly, many French trainees (conservators, architects, egyptologists and archaeologists) were welcomed into the CFEETK, to practice fruitful exchanges in joint field programmes and activities.

Access to the library of the Centre used to receive young MoA inspectors preparing Masters (especially from Univ. of Qena). Guidance and assistance to bibliographic research are regularly taught by S. Biston-Moulin (CNRS-CFEETK).

Two conservators MoA-CFEETK attended training on coins conservation-restoration techniques organized by ARCE. A young inspector of the MoA-CFEETK received support from the Centre to take French courses at the IFE in Cairo to better prepare his registration in Master in 2017 at the University of Rennes.

List of training programmes (courses from one week to ten days):

- Training in epigraphic records: 10 trainees (MoA inspectors Karnak);
- Training in image processing software: 10 trainees (MoA inspectors Karnak);
- Introduction to digital photography: 10 trainees (MoA inspectors Karnak);
- Training in drawing software: 10 trainees (inspectors and conservators MoA Karnak);
- Initiation and training in surveying: 2 trainees (MoA inspectors Karnak);
- Training in archaeology: 2 trainees (MoA inspectors Karnak);
- Training in conservation: 3 trainees (MoA conservators Karnak);
- French Course (French Institute of Cairo Egypt): 2 sessions (4/5 days), 15 to 20 trainees (MoA inspectors of Karnak, Luxor and Qurna), supplemented by a weekly course of 2 hours for three months (CFEETK funding).

6. PUBLICATIONS AND LECTURES

6.1. Selected publications of CFEETK members and associated missions (2016)

A short activity report of the CFEETK is published every sixth months in the revue *Egyptian Archaeology* (“Digging Diary”).

- BISTON-MOULIN S., THIERS Chr., *Le temple de Ptah à Karnak I. Relevé épigraphique (Ptah, n^{os} 1-191), II. Relevé photographique (J.-Fr. Gout), Travaux du CFEETK, BiGén 49, Cairo, 2016.*

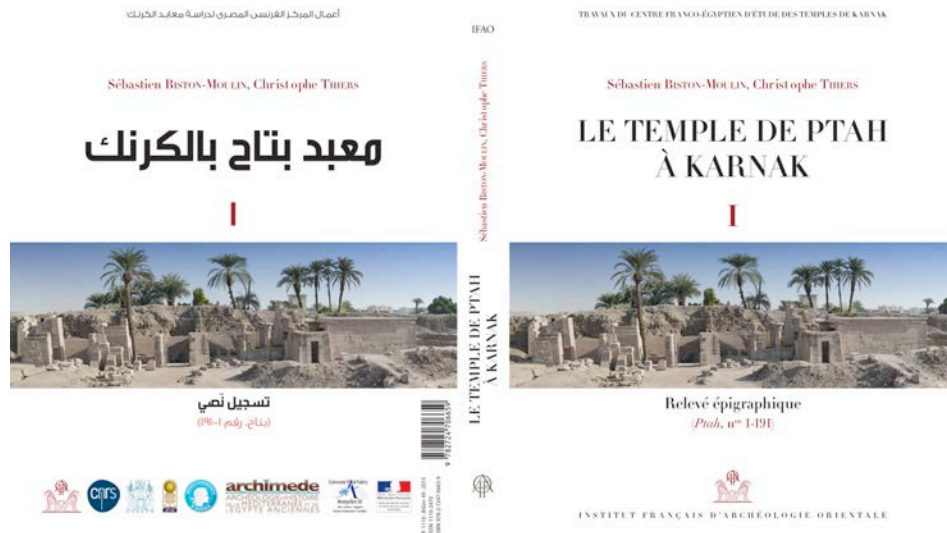

- BISTON-MOULIN S. (dir.), *Inventaire des monuments, objets, scènes et inscriptions des temples de Karnak*, Montpellier, 2016, 560 p. (PDF online : <http://www.cfeetk.cnrs.fr/karnak/?inventaire=y>).



- K. MADRIGAL (with J.-Cl. Goyon), *La Chambre des Ancêtres du temple d'Amon-Rê à Karnak. Lettres inédites d'Émile Prisse d'Avennes à Jacques-Joseph Champollion-Figeac*, Travaux du CFEETK, Paris, 2016.

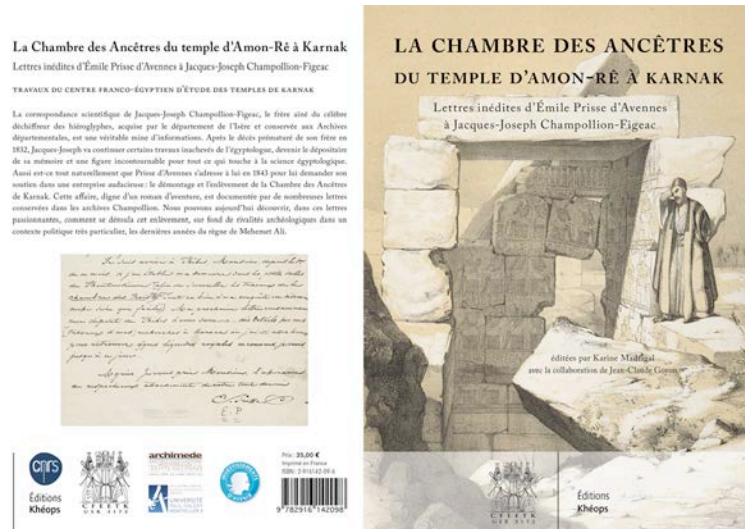

- DAVID R. (ed.), *Céramiques ptolémaïques de la région thébaine. Actes de la table ronde Theban Ceramics in Hellenistic Context, Karnak, les 28 et 29 septembre 2014*, Travaux du CFEETK, CCE 10, IFAO, Cairo, 2016.



- DAVID R. *et al.*, “Theban ceramics in Ptolemaic context - Fabrics classification”, p. 11-22.
- DAVID R., “La céramique ptolémaïque d’une zone annexe du temple de Ptah à Karnak”, p. 49-76.
- LICITRA N., DAVID R., “L’évolution des céramiques ptolémaïques à Karnak d’après la documentation du Trésor de Chabaka”, p. 77-121.
- MARCHAND S., “Catacombes » osiriennes de Ptolémée IV du temple d'Amon de Karnak, CFEETK. Céramiques ptolémaïques et romaines”, p. 123-148.
- MASSON A., “Ptolemaic ceramics of the Theban Region between tradition, imitation and innovation: The Priests’ Quarter as a study case”, p. 149-164.
- NAGUIB REDA M., “A Ptolemaic kitchen in front of the temples of Karnak”, p. 165-188.

- COULON L. (dir.), *La Cachette de Karnak. Nouvelles perspectives sur les découvertes de Georges Legrain*, BdE 161, Cairo, 2016.
- BOULET St., “Les productions céramiques de la Troisième Période intermédiaire : entre traditions et innovations”, *Égypte. Afrique & Orient* 81, 2016, p. 31-38.
- BOULET St., “La chapelle d’Osiris Ounnefer Neb-Djefau à Karnak : nouvelles avancées sur les développements des productions céramiques entre la Troisième Période intermédiaire et la Basse Époque”, *BCE* 26, 2016, p. 213-226.
- LICITRA N., “Gérer les richesses du temple à l’époque koushito-saïte. Les découvertes récentes dans le Trésor de Shabaqo à Karnak”, *Égypte. Afrique & Orient* 81, 2016, p. 53-58.
- SALVADOR Ch., “Graffiti and sacred space: New Kingdom expressions of individuality in the court of the seventh pylon at Karnak”, in M. Ullmann (ed.), *10. Ägyptologische Tempeltagung. Ägyptische Tempel zwischen Normierung und Individualität*, KSGH 3,5, 2016, p. 111-128.

Cahiers de Karnak 15, 2015 have been published in 2016 under the press of Ministry of Antiquities.

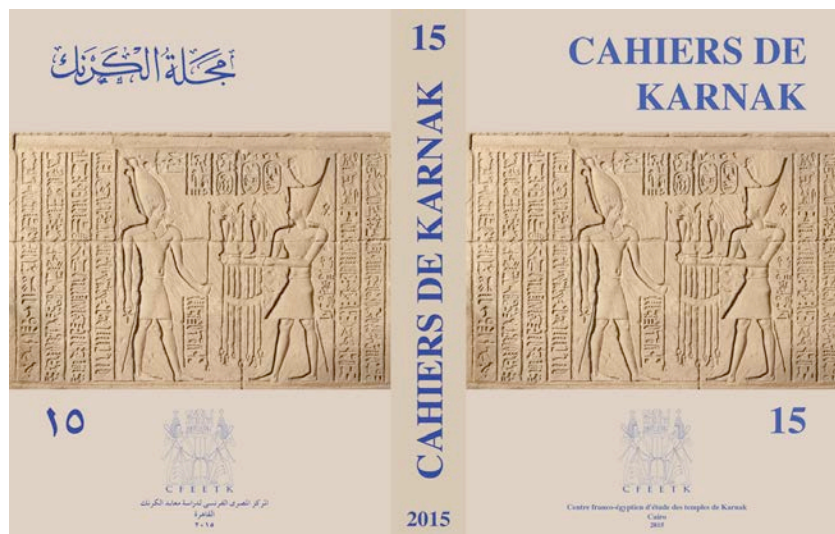

To be published

- CHARLOUX G., THIERS Chr., “The Afterlife of Egyptian Statues: New Evidence From a Cache in the Temple of Ptah at Karnak”, *Antiquity*, forthcoming.
- CHARLOUX G., THIERS Chr., “The Early Temple of Ptah at Karnak”, *Egyptian Archaeology*, forthcoming.
- DAVID R., “Quelques pratiques potières de l’Égypte ptolémaïque d’après la documentation de Karnak”, in *Actes du colloque international l’objet égyptien, source de la recherche, École du Louvre, les 17, 18, 19 juin 2015*, forthcoming.
- THIERS Chr., “A Case-Study of a Technique. The So-Called Karnak Technique”, in V. Davies, D. Laboury, (eds.), *Oxford Handbook of Egyptian Epigraphy and Palaeography*, Oxford, forthcoming.

6.2. Colloquium and lectures

- 11.02.2016: *Conservation Congress in Luxor* (Conservation of Theban Temple and Tombs), Luxor, Momification Museum, Musée de la momification: A. Garric, C. Bourse, “Anastylis and Conservation Issues in Karnak”.
- 16.03.2016: *Forum Méditerranée. Sciences sociales et humaines* (Marseille, LabexMed, en collaboration avec les labex ArcHiMedE, OT-Med, Resmed et le MuCEM):⁴¹ Chr. Thiers, G. Charloux, B. Durand, “Le temple de Ptah à Karnak : cultes et édification de l’espace sacré”.
- 17.03.2016: *Forum Méditerranée. Sciences sociales et humaines* (Marseille, LabexMed, en collaboration avec les labex ArcHiMedE, OT-Med, Resmed et le MuCEM): R. David, “Interactions culturelles et échanges économiques dans les zones marginales de l’empire byzantin : la contribution des céramiques de la région thébaine”.
- 17.03.2016: *Forum Méditerranée. Sciences sociales et humaines* (Marseille, LabexMed, en collaboration avec les labex ArcHiMedE, OT-Med, Resmed et le MuCEM): S. Biston-Moulin, “Le Projet *Karnak*. Système d’Indexation des Textes Hiéroglyphiques”.
- 24.04.2016, Karnak, Field School: G. Charloux, M. Abady et A. Nasseh, “Results of the 2014-2016 Excavation Seasons at Ptah Temple”.
- 26.05.2016, *The First Annual Meeting The Archaeological Missions in Egypt 2015-2016*, Cairo, MoA: Chr. Thiers, “The Archaeological Work of The Centre franco-égyptien d’étude des Temples de Karnak in Egypt (2015-2016)”.
- 14.07.2016 : *Annual Egyptological Colloquium. Statues in contexts: production, meaning and (re)uses*, British Museum, London: G. Charloux, “Ritual Burial of a God Statue at the Temple of Ptah in Karnak”.
- 14-15.07.2016, *The Levantine Ceramics Project 2016 Workshop 2. Pottery of Egypt in the Ptolemaic, Roman and Byzantine Periods*, Danish Institute of Archaeology, Athens: R. David, “Karnak”.
- 29.09.2016, *Thebes in the First Millenium BC*,⁴² South Asasif Conservation Project, MoA, Egypt Exploration Society, Luxor, Momification Museum: St. Boulet, “Ceramic Industry Developments in the Theban Area during the Twenty-fifth Dynasty: Between Traditions and Innovations”.
- 29.09.2016, *Thebes in the First Millenium BC* , South Asasif Conservation Project, MoA, Egypt Exploration Society, Luxor, Momification Museum: J. Hourdin, « The Kushite Kiosks of Karnak and Luxor: A Cross-over Study ».
- 29.09.2016, *Thebes in the First Millenium BC*, South Asasif Conservation Project, MoA, Egypt Exploration Society, Louqsor, Luxor, Momification Museum: Chr. Thiers, “Karnak in the First Millennium BC. CFEETK Recent Finds and Current Projects”.
- 29.09.2016, *Thebes in the First Millenium BC*, South Asasif Conservation Project, MoA, Egypt Exploration Society, Luxor, Momification Museum: L. Coulon, A. Hallmann, Fr. Payraudeau, “The Osirian Chapels at Karnak: Recent Epigraphic Work and Historical and Art Historical Studies”.
- 29.09.2016, *Thebes in the First Millenium BC*, South Asasif Conservation Project, MoA, Egypt Exploration Society, Luxor, Momification Museum: E. Nagy, “The Kushites in Karnak: The Chapel of Osiris Ptah Neb ankh”.

⁴¹ https://forum-med.sciencesconf.org/data/pages/Panorama_recherches_etudes_med_SHS_2016.pdf

⁴² <http://southasasif.com/conference2016.html>

6.3. Press releases

- French TV TF1 evening news, 28th of february 2016: reconstruction programmes of the CFEETK (A. Garric)
- French TV France 2 evening news: 3rd of April 2016: conservation-restoration programmes of the CFEETK (C. Bourse).⁴⁴
- French TV programme *Secrets d'Histoire* (France 2): 30th of August 2016: the chapel of Alexander the Great (Chr. Thiers).
- French TV programme *Mediterraneo* (France 3): 24th and 25th of September 2016: reconstruction programmes, conservation-restoration programmes and online *Karnak Project*.⁴⁵
- <https://www.youtube.com/watch?v=IIatWR1frSU>

7. CFEETK MEMBERS

MoA members

- Dr. Mohamed ABDEL AZIZ General director of Luxor and Upper Egypt, co-director of the CFEETK
- Dr. Mustafa WAZIRI General director of Luxor antiquities
- Ameen AMMAR General director of Karnak Temples
- Abder Raheem KHAZAFI Director of Karnak Temples
- Badri ABD AL SATTAR General director of scientific research
- Tarek MILAD ZIKRI Chief architect of Upper Egypt
- Ahmed ABDEL NASSER Chief conservator
- Fawzy HELMI Director of Karnak Temple
- Mona FATHI Director of Karnak Temple
- Ghada IBRAHIM Chief inspector, in charge of foreign missions
- Mamduh ABD EL GHASSUL Draftman
- Magdi LOUIZ Documentation officer
- Karima DOWI ABD AL-RADI Photographer
- Ahmed RUBY Assistant photographer
- Mahmud FARUK Raïs

Assistant members

- Tayeb GHARIB Chief inspector
- Moamen SAHAD Chief inspector
- Salah AL-MASEKH Chief inspector
- Emad ABDEL HARIH Inspector
- Ashraf GAD EL-RAB Inspector
- Ahmed NASSEH Inspector
- Mona ABADI Inspector
- Yasser MOSTAFA Inspector
- Mohamed BADAWY Inspector
- Salwa NUR ED-DINE Inspector
- Hoda ABD EL-SADEK Inspector
- Hala HASSAN Inspector

⁴⁴ http://www.francetvinfo.fr/monde/egypte/egypte-antique-une-passion-francaise_1388705.html

⁴⁵ <http://france3-regions.francetvinfo.fr/provence-alpes/emissions/mediterraneo/patrimoine-mediterraneen-1-egypte-protege-ses-antiquites.html>

- Amira ABD EL-KUDUS	Inspector
- Peter EL-FADI	Inspector
- Wahid YUSSEF	Inspector
- Asma MUSTAFA	Inspector
- Sohad ALI	Inspector
- Ali ARAFAT	Inspector
- Sadham SADIK	Inspector
- Abul Hassan MOHAMED	Inspector

CNRS members

- Dr. Chr. THIERS	Director of the USR 3172, co-director of the CFEETK
- Dr. S. BISTON-MOULIN	Documentalist-egyptologist
- Dr. G. CHARLOUX	Archaeologist (till September 2016)
- A. GARRIC	Stone-cutter
- J. MAUCOR	Photographer (till June 2016)
- V. PUELLE	Administrator
- C. BOURSE	Conservator
- É. SAUBESTRE	Photographer (from November 2016)

Univ. Paul-Valéry Montpellier 3 - LabEx Archimede, programme « Investissement d'avenir », ANR-11-LABX-0032-01

- Dr. St. BOULET	Ceramologist
- Dr. G. DEMBITZ	Egyptologist
- Dr. B. DURAND	Archaeologist
- Dr. J. HOURDIN	Egyptologist
- Dr. Ch. LABARTA	Egyptologist
- Fl. PIROU	Epigraphist

International Volunteers MAEDI

- P. MEGARD	Surveyor
- C. DE OLIVEIRA	Conservator (till October 2016)
- L. ANTOINE	Conservator (from October 2016)

CNRS trainees and missions 2016

- R. BETBEZE	Egyptologist
- S. CASSOR-PFEIFFER	Egyptologist
- Fl. CAMUS	Archaeologist
- F. HAMONIC	Egyptologist
- M. RIOU	Archaeologist

8. ACADEMIC COLLABORATIONS

France

- UMR 5140 – Univ. Paul Valéry-Montpellier 3 (Labex Archimede IA-ANR-11-LABX-0032-01)
- EPHE EA 4519
- UMR 5189 – HiSoma Univ. Lyon 2
- UMR 8164 – Halma Univ. Lille 3
- UMR 8152 – Univ. Paris IV Sorbonne
- USR 3134 – Centre d'études alexandrines (CeAlex)
- Institut français d'archéologie orientale (Ifao)

Other countries

- American Research Center in Egypt (ARCE)
- Chicago House (Luxor)
- Univ. of Tübingen
- Univ. Libre de Bruxelles
- Univ. of Quebec (Montréal)
- Univ. of Memphis (Tennessee)
- Univ. of Oxford

8. SUBMITTED PROGRAMMES OF THE CFEETK FOR 2017

The main 2016 programmes will continue during the season 2017, with new epigraphic work focussed on the study of loose blocks (studies before future expected reconstruction programmes):

1. CONSERVATION AND RECONSTRUCTION PROGRAMMES

- 1.1. Conservation at the *Akh-menu*: following the work at the Alexander's Chapel, its vestibule and the three adjacent rooms, the programme will continue on the neighbouring areas of the *Akh-menu* and in the columned hall (removing of old cement and new stone treatment).
- 1.2. Conservation and reconstruction of the walls of the 7th Pylon courtyard, which will be the main reconstruction programme of 2017. After an Egyptological study (Fr. Le Saout, G. Dembitz), more than 230 blocks have been identified, restored, cleaned and stored in the courtyard, and will be put back upon the wall in a new masonry.
- 1.3. Conservation of the blocks belonging to the Kiosk of Osorkon uncovered in front of Khonsu Temple during the 1970's (stored upon mastabas east to the Open Air Museum).

2. ARCHAEOLOGY AND EPIGRAPHY

- 2.1. Excavation in the area of the Ptah Temple (southern and eastern areas).
- 2.2. Excavation at the Treasury of Shabaqo.
- 2.3. Excavation and epigraphic survey at the Osirian chapels.
- 2.4. Epigraphic survey of the *Akh-menu*.
- 2.5. Epigraphic survey of the 8th Pylon.
- 2.6. Epigraphic survey of the graffiti in the courts of the 7th and 8th Pylons.
- 2.7. Epigraphic survey of the columns of the Great Hypostyle Hall.
- 2.8. Epigraphic survey of the sphinx of Pinudjem.
- 2.9. Epigraphic survey of the Gate of the 2nd Pylon and of the Kiosk of Taharqo.
- 2.10. Epigraphic and architectural survey of the Monuments of Amenhotep I.
- 2.11. Epigraphic survey of the blocks of the gate south to the Bubastite Court.
- 2.12. Epigraphic survey of the blocks of the 2nd Pylon.
- 2.13. Epigraphic survey of the blocks belonging to the Edifice of Taharqo by the Sacred Lake.
- 2.14. Epigraphic survey of the 7th Pylon.
- 2.15. Epigraphic survey of the Opet Temple.

3. ANALYSIS

- 3.1. Field and laboratory (Karnak "ARCE Lab") analysis of mortars and plasters from Karnak temples.
- 3.2. Field and laboratory (Karnak "ARCE Lab") analysis of ceramic potsherds and metal artefacts.

3.3. Sending of samples (potsherds, charcoals, vegetal and faunal remains, stones, metal...) to Cairo (IFAO Laboratory C14) from excavations of the Ptah Temple, Courtyard of the 10th pylon and previous excavations (central area of Karnak temple).

4. ARCHIVES

4.1. Ongoing programme of photographic survey of all Karnak monuments to provide online high resolution photographs.

4.2. In order to keep data in the CFEETK archives, it will be asked to all the heads of missions to let a digital copy of all documents done during the mission.